

TECHNICAL MANUAL

**UNIT, FORWARD INTERMEDIATE AND
REAR INTERMEDIATE MAINTENANCE
REPAIR PARTS AND SPECIAL TOOLS LIST**

FOR

**COMPRESSOR UNIT,
RECIPROCATING, 5CFM,
175 PSI, ELECTRIC
MOTOR DRIVEN**

**MODEL E23CV7A
NSN: 4310-01-165-6676**

HEADQUARTERS, DEPARTMENT OF THE ARMY

10 MARCH 1986

CHANGE }
NO. 1 }

HEADQUARTERS
DEPARTMENT OF THE ARMY
WASHINGTON, D.C., 20 January 1988

Unit, Forward Intermediate and
Rear Intermediate Maintenance
Repair Parts and Special Tools List

COMPRESSOR UNIT
RECIPROCATING, 5CFM,
175 PSI, ELECTRIC
MOTOR DRIVEN

MODEL E23CV7A
NSN: 4310-01-165-6676

TM 5-4310-377-23P, 10 March 1986, is changed as follows:

1. Remove and insert pages as indicated below. The asterisk (*) to the left of the ITEM NO. column adjacent to the line item indicates the current change. An illustration change is indicated by a miniature pointing hand.

Remove pages

14-1 and Figure 15
I-1 and I-2
I-3 and I-4
I-5 and I-6

Insert pages

14-1 and Figure 15
I-1 and I-2
I-3 and I-4
I-5 and I-6

2. Retain this sheet in front of manual for reference purposes.

By Order of the Secretary of the Army:

CARL E. VUONO
General, United States Army
Chief of Staff

Official:

R. L. DILWORTH
Brigadier General, United States Army
The Adjutant General

DISTRIBUTION:

To be distributed in accordance with DA Form 12-25A, Unit, Intermediate Direct Support and Intermediate General Support maintenance requirements for Compressor Unit, Reciprocating, Electric, 5 CFM, 175 PSI (E23CV7A).

Unit, Forward Intermediate and
Rear Intermediate Maintenance
Repair Parts and Special Tools List
FOR
COMPRESSOR UNIT, RECIPROCATING, 5 CFM,
175 PSI, ELECTRIC MOTOR DRIVEN

MODEL E23CV7A
NSN 4310-01-165-6676

REPORTING OF ERRORS AND RECOMMENDING IMPROVEMENTS

You can help improve this manual. If you find any mistakes or if you know of a way to improve the procedures, please let us know. Mail your letter, DA Form 2028, (Recommended Changes to Publications and Blank Forms) or DA Form 2028-2 located in the back of this manual direct to: Commander, U.S. Army Troop Support Command, ATTN: AMSTR-MCTS, 4300 Goodfellow Blvd., St. Louis, MO 63120-1798. A reply will be furnished to you.

TABLE OF CONTENTS

	Page	Illus Figure
Section I INTRODUCTION	1	
Section II REPAIR PARTS LIST	1-1	
Group 01 Motor Controls.....	1-1	
Starter, Electric Motor and Wiring.....	1-1	1
Pressure Switch.....	2-1	2
Group 02 Compressor Drive.....	3-1	
Belt Guard Assembly	3-1	3
Matched V Belts Set and Drive Pulleys.....	4-1	4
Group 03 Compressor Assembly	5-1	
Compressor Mounting	5-1	5
Air Cleaner.....	6-1	6
Oil Filler, Cap, and Plug.....	7-1	7
Tube Assemblies	8-1	8
Intake and Exhaust Valves	9-1	9
First Stage Piston, Connecting Rod, and Cylinder Block.....	10-1	10
Second Stage Piston, Connecting Rod, and Cylinder Block.....	11-1	11
Crankshaft, Bearing, and Oil Seals.....	12-1	12
Group 04 Electric Motor	13-1	
Electric Motor Mounting.....	13-1	13
Electric Motor	14-1	14
Group 05 Air Receiver System	15-1	15
Relief Valve and Plug.....	16-1	16
Group 06 Air Discharge System.....	17-1	
Air Discharge System.....	17-1	17
Group 07 Data Plates.....	18-1	
Data Plates.....	18-1	18

TABLE OF CONTENTS (Cont)

		Page	Illus Figure
Group 08	Bulk	Bulk-1	Bulk
Section III	SPECIAL TOOLS LIST (NOT APPLICABLE)		
Section IV	NATIONAL STOCK NUMBERS AND REFERENCE NUMBER INDEX.....	I-1	

**UNIT, FORWARD INTERMEDIATE AND
REAR INTERMEDIATE MAINTENANCE
REPAIR PARTS AND SPECIAL TOOLS LIST**

Section I. INTRODUCTION

1. SCOPE. This RPSTL lists and authorizes spares and repair parts; special tools; special test, measurement, and diagnostic equipment (TMDE); and other special support equipment required for performance of unit and intermediate maintenance of the Compressor Unit. It authorizes the requisitioning, issue, and disposition of spares, repair parts and special tools as indicated by the source, maintenance and recoverability (SMR) codes.

2. GENERAL. In addition to this section, Introduction, this Repair Parts and Special Tools List is divided into the following sections:

a. Section II. Repair Parts List. A list of spares and repair parts authorized by this RPSTL for use in the performance of maintenance. The list also includes parts which must be removed for replacement of the authorized parts. Parts lists are composed of functional groups in ascending alphanumeric sequence, with the parts in each group listed in ascending figure and item number sequence. Bulk materials are listed in item name sequence. Repair parts kits are listed separately in their own functional group within Section II. Repair parts for repairable special tools are also listed in this section. Items listed are shown on the associated illustration(s) /figure(s).

b. Section III. Special Tools List. A list of special tools, special TMDE, and other special support equipment authorized by this RPSTL (as indicated by Basis of Issue (BOI) information in DESCRIPTION AND USABLE ON CODE column) for the performance of maintenance.

c. Section IV. National Stock Number and Part Number Index. A list, in National item identification number (NIIN) sequence, of all National stock numbered items appearing in the listing, followed by a list in alphanumeric sequence of all part numbers appearing in the listings. National stock numbers and part numbers are cross-referenced to each illustration figure and item number appearance.

3. EXPLANATION OF COLUMNS (SECTIONS II AND III).

a. ITEM NO. (Column (1)). Indicates the number used to identify items called out in the illustration.

b. SMR Code (Column (2)). The Source, Maintenance, and Recoverability (SMR) code is a 5-position code containing supply/requisitioning information, maintenance category authorization criteria, and disposition instruction, as shown in the following breakout:

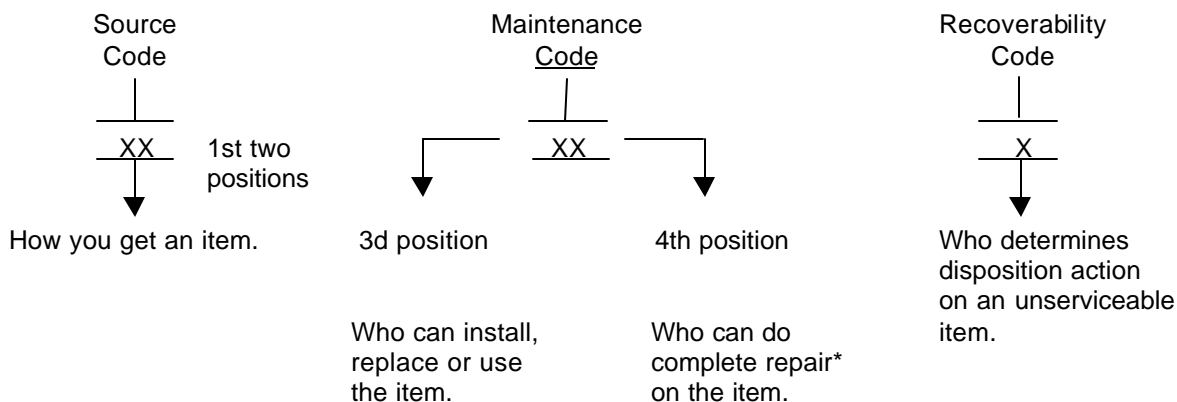

*Complete Repair: Maintenance capacity, capability, and authority to perform all corrective maintenance tasks of the "Repair" function in a use/user environment in order to restore serviceability to a failed item.

(1) **Source Code.** The source code tells you how to get an item needed for maintenance, repair, or overhaul of an end item/equipment. Explanations of source codes follows:

Code	Explanation
<ul style="list-style-type: none"> PA PB PC** PD PE PF PG 	<p>Stocked items; use the applicable NSN to request/requisition items with these source codes. They are authorized to the category indicated by the code entered in the 3d position of the SMR code.</p> <p>**NOTE: Items coded PC are subject to deterioration.</p>
<ul style="list-style-type: none"> KD KF KB 	<p>Items with these codes are not to be requested/requisitioned individually. They are part of a kit which is authorized to the maintenance category indicated in the 3d position of the SMR code. The complete kit must be requisitioned and applied.</p>
<ul style="list-style-type: none"> MO - (Made at unit Maintenance Level) MF - (Made at Intermediate (DS) Level) MH - (Made at Intermediate (GS) Level) ML - (Made at Specialized Repair Activity (SRA)) MD - (Made at Depot) 	<p>Explanation</p> <p>Items with these codes are not to be requested/requisitioned individually. They must be made from bulk material which is identified by the part number in the DESCRIPTION and USABLE ON CODE (UOC) column and listed in the Bulk Material group of the repair parts list in the RPSTL. If the item is authorized to you by the 3d position code of the SMR code, but the source code indicates it is made at a higher level, order the item from the higher level of maintenance.</p>
<ul style="list-style-type: none"> AO - (Assembled by Unit Maintenance Level) AF - (Assembled by Intermediate (DS) Level) AH - (Assembled by Intermediate (GS) Level) AL - (Assembled by SRA) AD - (Assembled by Depot) 	<p>Explanation</p> <p>Items with these codes are not to be requested/requisitioned individually. The parts that make up the assembled item must be requisitioned or fabricated and assembled at the level of maintenance indicated by the source code. If the 3d position code of the SMR code authorizes you to replace the item, but the source code indicates the items are assembled at a higher level, order the item from the higher level of maintenance.</p>

Code Explanation

- XA - Do not requisition an "XA" -coded item. Order its next higher assembly. (Also, refer to the NOTE below.)
- XB - If an "XB" item is not available from salvage, order it using the FSCM and part number given.
- XC - Installation drawing, diagram, instruction sheet, field service drawing, that is identified by manufacturer's part number.
- XD - Item is not stocked. Order an "XD" -coded item through normal supply channels using the FSCM and part number given, if no NSN is available.

NOTE

Cannibalization or controlled exchange, when authorized, may be used as a source of supply for items with the above source codes, except for those source coded "XA" or those aircraft support items restricted by requirements of AR 700-42.

(2) Maintenance Code. Maintenance codes tells you the level(s) of maintenance authorized to USE and REPAIR support items. The maintenance codes are entered in the third and fourth positions of the SMR Code as follows:

(a) The maintenance code entered in the third position tells you the lowest maintenance level authorized to remove, replace, and use an item. The maintenance code entered in the third position will indicate authorization to one of the following levels of maintenance.

Code	Application/Explanation
C	-Crew or operator maintenance done within unit maintenance.
O	-Unit maintenance level can remove, replace, and use the item.
F	-Intermediate (DS) level can remove, replace, and use the item.
H	-Intermediate (GS) level can remove, replace, and use the item.
L	-Specialized repair activity can remove, replace, and use the item.
D	-Depot level can remove, replace, and use the item.

(b) The maintenance code entered in the fourth position tells whether or not the item is to be repaired and identifies the lowest maintenance level with the capability to do complete repair (i.e., perform all authorized repair functions.) NOTE: Some limited repair may be done on the item at a lower level of maintenance, if authorized by the Maintenance Allocation Chart (MAC) and SMR codes. This position will contain one of the following maintenance codes.

Code	Application/Explanation
O	-Unit maintenance is the lowest level that can do complete repair of the item.
F	-Intermediate (DS) is the lowest level that can do complete repair of the item.

Code	Application/Explanation
H	-Intermediate (GS) is the lowest level that can do complete repair of the item.
L	-Specialized repair activity is the lowest level that can do complete repair of the item.
D	-Depot is the lowest level that can do complete repair of the item.
Z	-Nonreparable. No repair is authorized.
B	-No repair is authorized. (No parts or special tools are authorized for the maintenance of a "B" coded item). However, the item may be reconditioned by adjusting, lubricating, etc., at the user level.

(3) Recoverability Code. Recoverability codes are assigned to items to indicate the disposition action on unserviceable items. The recoverability code is entered in the fifth position of the SMR Code as follows:

Recoverability Codes	Application/Explanation
Z	-Nonreparable item. When unserviceable, condemn and dispose of the item at the level of maintenance shown in 3d position of SMR Code.
O	-Reparable item. When uneconomically repairable, condemn and dispose of the item at unit level.
F	-Reparable item. When uneconomically repairable, condemn and dispose of the item at the Intermediate (DS) level.
H	-Reparable item. When uneconomically repairable, condemn and dispose of the item at the Intermediate (GS) level.
D	-Reparable item. When beyond lower level repair capability, return to depot. Condemnation and disposal of item not authorized below depot level.
L	-Reparable item. Condemnation and disposal not authorized below specialized repair activity (SRA).
A	-Item requires special handling or condemnation procedures because of specific reasons (e.g., precious metal content, high dollar value, critical material, or hazardous material). Refer to appropriate manuals/directives for specific instructions.

c. FSCM (Column (3)). The Federal Supply Code for Manufacturer (FSCM) is a 5-digit numeric code which is used to identify the manufacturer, distributor, or Government agency, etc., that supplies the item.

d. PART NUMBER (Column (4)). Indicates the primary number used by the manufacturer, (individual, company, firm, corporation, or Government activity), which controls the design and characteristics of the item by means of its engineering drawings, specifications standards, and inspection requirements to identify an item or range of items.

NOTE

When you use a NSN to requisition an item, the item you receive may have a different part number from the part ordered.

- e. **DESCRIPTION AND USABLE ON CODE (UOC) (Column (5)).** This column includes the following information:
- (1) The Federal item name and, when required, a minimum description to identify the item.
 - (2) The physical security classification of the item is indicated by the parenthetical entry, e.g., Phy Sec C1 Confidential, Phy Sec C1 (S) - Secret, Phy Sec C1 (T) - Top Secret.
 - (3) Items that are included in kits and sets are listed below the name of the kit or set.
 - (4) Spare/repair parts that make up an assembled item are listed immediately following the assembled item line entry.
 - (5) Part numbers for bulk materials are referenced in this column in the line item entry for the item to be manufactured/fabricated.
 - (6) When the item is not used with all serial numbers of the same model, the effective serial numbers are shown on the last line(s) of the description (before UOC).
 - (7) The usable on code, when applicable (see paragraph 5, Special Information).
 - (8) In the Special Tools List section, the basis of issue (BOI) appears as the last line(s) in the entry for each special tool, special TMDE, and other special support equipment. When density of equipments supported exceeds density spread indicated in the basis of issue, the total authorization is increased proportionately.
 - (9) The statement "END OF FIGURE" appears just below the last item description in Column 5 for a given figure in both Section II and Section III.

f. **QTY (Column (6)).** The QTY (quantity per figure column) indicates the quantity of the item used in the breakout shown on the illustration figure, which is prepared for a functional group, subfunctional group, or an assembly. A "V" appearing in this column in lieu of a quantity indicates that the quantity is variable and may vary from application to application.

4. EXPLANATION OF COLUMNS (SECTION IV).

a. NATIONAL STOCK NUMBER (NSN) INDEX.

- (1) **STOCK NUMBER column.** This column lists the NSN by National item identification number NSN NSN (NIIN) sequence. The NIIN consists of the last nine digits of the NSN, i.e. (5305-01-574-1467).
NIIN
When using this column to locate an item, ignore the first 4 digits of the NSN. However, the complete NSN should be used when ordering items by stock number.
- (2) **FIG. column.** This column lists the number of the figure where the item is identified/located. The figures are in numerical order in Section II and Section III.
- (3) **ITEM column.** The item number identifies the item associated with the figure listed in the adjacent FIG. column. This item is also identified by the NSN listed on the same line.

b. PART NUMBER INDEX. Part numbers in this index are listed by part number in ascending alphanumeric sequence (i.e., vertical arrangement of letter and number combination which places the first letter or digit of each group in order A through Z, followed by the numbers 0 through 9 and each following letter or digit in like order).

- (1) **FSCM column.** The Federal Supply Code for Manufacturer (FSCM) is a 5-digit numeric code used to identify the manufacturer, distributor, or Government agency, etc., that supplies the item.
- (2) **PART NUMBER column.** Indicates the primary number used by the manufacturer (individual, firm, corporation, or Government activity), which controls the design and characteristics of the item by means of its engineering drawings, specifications standards, and inspection requirements to identify an item or range of items.
- (3) **STOCK NUMBER column.** This column lists the NSN for the associated part number and manufacturer identified in the PART NUMBER and FSCM columns to the left.
- (4) **FIG. column.** This column lists the number of the figure where the item is identified/located in Sections II and III.
- (5) **ITEM column.** The item number is that number assigned to the item as it appears in the figure referenced in adjacent figure number column.

5. SPECIAL INFORMATION.

a. USABLE ON CODE. The usable on code appears in the lower left corner of the Description column heading. Usable on codes are shown as "UOC:....." in the Description Column (justified left) on the first line applicable item description/nomenclature. Uncoded items are applicable to all models.

b. ASSOCIATED PUBLICATIONS. The publication listed below pertains to the Compressor Unit and its components.

Publication	Short Title
TM 5-4310-377-13	Compressor Unit, Reciprocating, 5CFM, 175 PSI, Electric Motor Driven

6. HOW TO LOCATE REPAIR PARTS.

a. When National Stock Number or Part Number is NOT Known.

- (1) **First.** Using the table of contents, determine the assembly group or subassembly group to which the item belongs. This is necessary since figures are prepared for assembly groups and subassembly groups, and listings are divided into the same groups.
- (2) **Second.** Find the figure covering the assembly group or subassembly group to which the item belongs.
- (3) **Third.** Identify the item on the figure and note the item number.
- (4) **Fourth.** Refer to the Repair Parts List for the figure to find the part number for the item number noted on the figure.
- (5) **Fifth.** Refer to the Part Number Index to find the NSN, if assigned.

b. When National Stock Number or Part Number is Known:

- (1) **First.** Using the Index of National Stock Numbers and Part Numbers, find the pertinent National Stock Number or Part Number. The NSN index is in National Item Identification Number (NIIN) sequence (see 4a(1)). The part numbers in the Part Number index are listed in ascending alphanumeric sequence (see paragraph 4b). Both indexes cross-reference you to the illustration figure and item number of the item you are looking for.
- (2) **Second.** After finding the figure and item number, verify that the item is the one you are looking for, then locate the item number in the repair parts list for the figure.

7. ABBREVIATIONS. Abbreviations used in this manual are listed in MIL-STD-12.

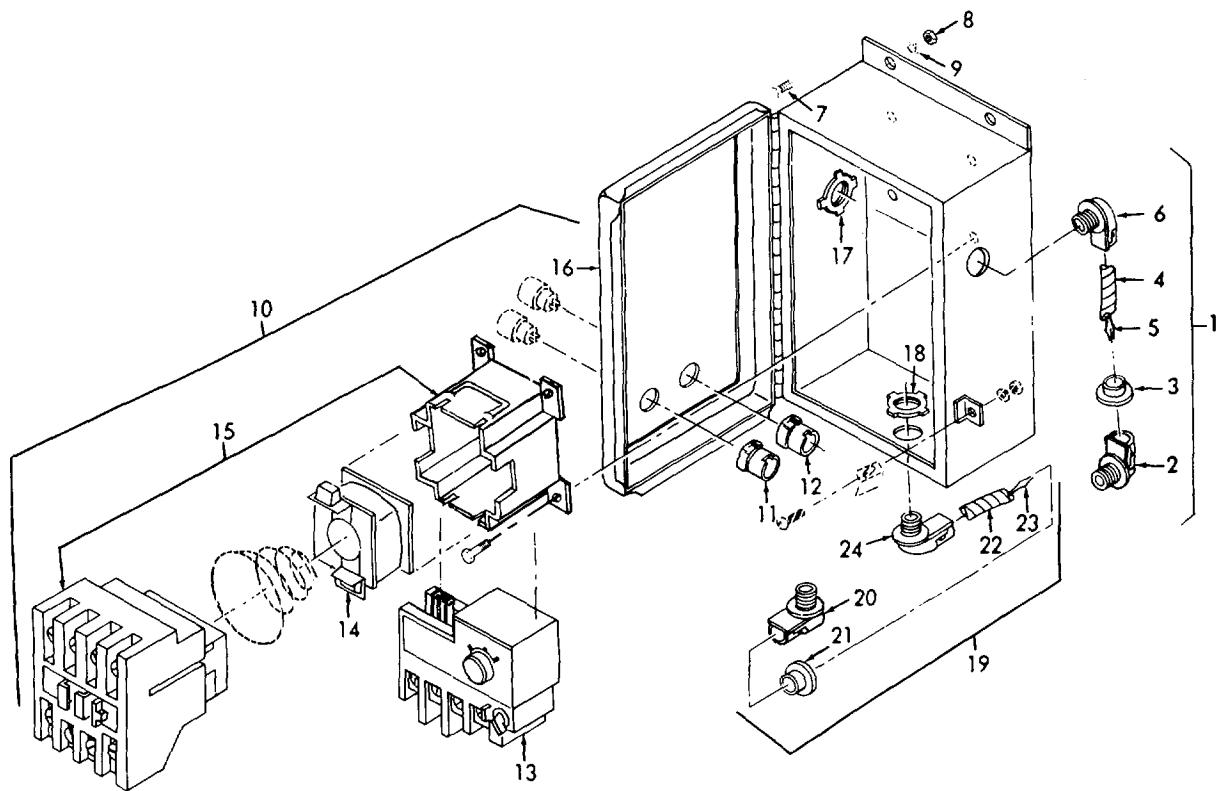

Figure 1. Electric Starter Motor and Wiring

SECTION II

TM 5-4310-377-23P

(1) ITEM NO	(2) SMR CODE	(3) FSCM	(4) PART NUMBER	(5) DESCRIPTION AND USABLE ON CODE (UOC)	(6) QTY
GROUP 01 MOTOR CONTROLS					
FIG. 1 STARTER, ELECTRIC MOTOR AND WIRING					
1	XBOOO	55921	0F606	WIRE ASSEMBLY, MOTOR.....	1
2	PAOZZ	03743	7246V	.BOX CONNECTOR, ELEC, 1/2 IN KNOCK- OUT X 1/2 IN FLEX CONDUIT 45 DEG ELBOW.....	1
3	PAOZZ	59730	393	.INSULATOR, BUSHING.....	2
4	XBOZZ	55921	VE1031-14	.CONDUIT, FLEX, 1/2 X IN X 14 IN STEEL, GALVANIZED.....	14
5	MOOZZ	55921	VE1006-24	.WIRE, ELEC, 10 AWG STRANDED COPPER 24 IN LONG, MAKE FROM NSN 6145-00-578-7513.....	1
6	PAOZZ	78229	XC-491	.BOX CONNECTOR, ELEC 112 IN KNOCK- OUT X 1/2 IN FLEX CONDUIT 90 DEG ELBOW.....	1
7	PAOZZ	96906	MS90728-6	SCREW, CAP, HEXAGON STARTER MTG.....	4
8	PAOZZ	96906	MS51967-2	NUT, PLAIN, HEXAGON, STARTER MTG.....	4
9	PAOZZ	96906	MS35338-44	WASHER, LOCK, STARTER MTG.....	4
10	PBOOO	52034	CA3-2P-23-120 AC&CT3-32A- M12-H0A	STARTER, MOTOR.....	1
11	PAOZZ	52034	DTD2-22-72-DE1- 10	.SWITCH, ROTARY, ON/OFF.....	1
12	PAOZZ	52034	DT2RRESETDC1	.SWITCH, PUSH.....	1
13	PAOZZ	52034	CT3-32A	.RELAY, THERMAL.....	1
14	PAOZZ	52034	22.601.304-120V	.COIL, ELEC.....	1
15	PAOZZ	52034	CA3-23	.CONTACTOR, MAGNETIC.....	1
16	XBOZZ	52034	1414PHG6	.BOX ASSEMBLY.....	1
17	PAOZZ	88044	AN3066-8	.LOCKNUT, ELEC, CONDUIT COUPLING, 1/2 IN.....	2
18	PAOZZ	11530	258-2384	.LOCKNUT, ELEC CONDUIT COUPLING, 1/2 IN.....	2
19	XBOOO	55921	0F607	WIRE ASSEMBLY, SWITCH.....	1
20	PAOZZ	03743	7380V	.BOX CONNECTOR, ELEC, 1/2 IN KNOCK-OUT X 3/8 IN FLEX CONDUIT 90 DEG BELOW.....	1
21	PAOZZ	59730	391	.INSULATOR, BUSHING.....	2
22	XBOZZ	55921	VE1015-11.5	.CONDUIT, FLEX, 3/8 IN STEEL 11 ¹ / ₂ IN LG.....	1
23	MOOZZ	55921	VE1037-24	.WIRE, ELEC, 18 AWG STRANDED COPPER, 24 IN LG, MAKE FROM NSN 6145-000-578-752.....	2
24	PAOZZ	03743	7245V	.BOX CONNECTOR, ELEC, 1/2 IN KNOCK-OUT X 3/8 IN FLEX CONDUIT 45 DEG.....	1
END OF FIGURE					

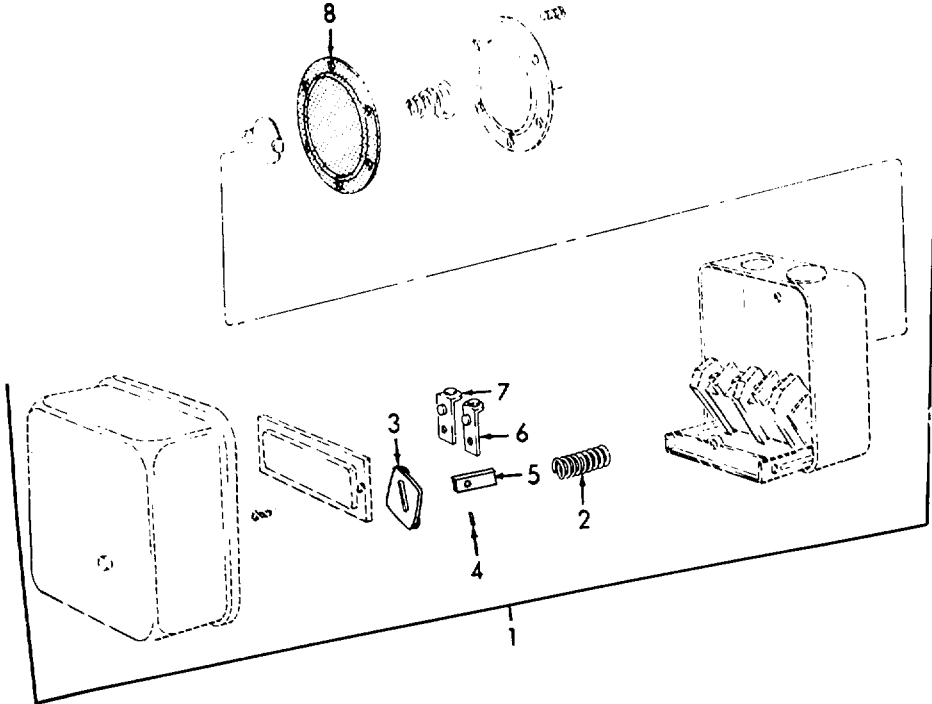

Figure 2. Pressure Switch

SECTION II

TM 5-4310-377-23P

(1) ITEM NO	(2) SMR CODE	(3) FSCM	(4) PART NUMBER	(5) DESCRIPTION AND USABLE ON CODE (UOC)	(6) QTY
				GROUP 01 MOTOR CONTROLS	
				FIG. 2 PRESSURE SWITCH	
1	PAOZZ	23826	69HAU1	SWITCH, PRESSURE, 3/8 FPT 165PSI CUT IN 195PSI CUT OUT.....	1
2	KFOZZ	23826	D27257-1	.SPRING (PART OF KIT, P/N 75HA69)	2
3	KFOZZ	23826	D817-2	.CONTACT, MOVABLE (PART OF KIT, P/N 75HA69) ..	2
4	KFOZZ	23826	D354-1	.PIN (PART OF KIT, P/N 75HA69)	2
5	KFOZZ	23826	D334-1	.ROD, PUSH (PART OF KIT, P/N 75HA69)	2
6	KFOZZ	23826	D661-0-8	.CONTACT, STATIONARY (PART OF KIT P/N 75HA69).....	4
7	KFOZZ	23826	D661-0-7	.CONTACT, STATIONARY (PART OF KIT P/N 75HA69).....	4
8	KFOZZ	23826	D274-1	.DIAPHRAGM, ELECT (PART OF KIT P/N 75HA69).....	1
	PAOZZ	23826	75HA69	REPAIR KIT, PRESSURE	1
				CONTACT, MOVABLE (2) 2-3	
				CONTACT, STATIONARY (4) 2-6	
				CONTACT, STATIONARY (4) 2-7	
				DIAPHRAGM, ELEC (1) 2-8	
				PIN (2) 2-4	
				ROD, PUSH (2) 2-5	
				SPRING (2) 2-2	
				END OF FIGURE	

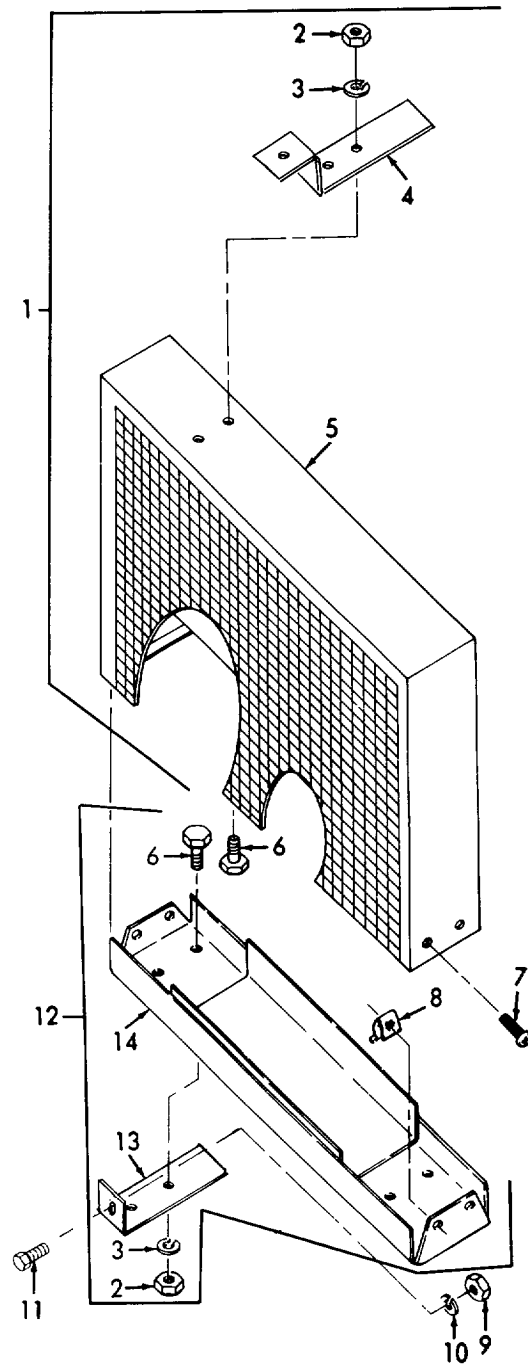

Figure 3. Belt Guard Assembly

SECTION II

TM 5-4310-377-23P

(1) ITEM NO	(2) SMR CODE	(3) FSCM	(4) PART NUMBER	(5) DESCRIPTION AND USABLE ON CODE (UOC)	(6) QTY
				GROUP 02 COMPRESSOR DRIVE	
				FIG. 3 BELT GUARD ASSEMBLY	
1	XBOOO	55921	CAC2238	GUARD ASSEMBLY, UPPER.....	1
2	PAOZZ	96906	MS51967-2	.NUT, PLAIN, HEXAGON, BRACKET MTG	6
3	PAOZZ	96906	MS35338-44	.WASHER, LOCK, BRACKET MTG, 1/4 IN.....	6
4	XBOZZ	55921	CAC2234	.BRACKET, SUPPORT.....	1
5	XBOZZ	55921	CAC2230	.FRAME, WELDMENT TOP.....	1
6	PAOZZ	96906	MS90728-6	.SCREW, CAP, HEXAGON, BRACKET MTG, 1/4-20	6
7	PAOZZ	96906	MS35206-261	SCREW, MACHINE, LOWER GUARD MTG, 10- 24 X 3/8 IN LONG.....	4
8	PAOZZ	78553	C1379-1024-1	NUT, SHEET SPRING, 10-24.....	4
9	PAOZZ	96906	MS51967-5	NUT, PLAIN, HEXAGON, LOWER GUARD MTG, 5/16 IN.....	2
10	PAOZZ	96906	MS35338-45	WASHER, LOCK, LOWER GUARD MTG STEEL CARBON ,5/16 IN.....	2
11	PAOZZ	96906	MS90728-32	BOLT, MACHINE, LOWER GUARD MTG 5/16- 18 X 3/4 IN LONG.....	2
12	XBOOO	55921	CAC2237	GUARD ASSEMBLY, LOWER.....	1
13	XBOZZ	55921	CAC2233	.BRACKET, SUPPORT, LOWER GUARD.....	2
14	XBOZZ	55921	CAC2231	.FRAME, WELDMENT, LOWER	1
				END OF FIGURE	

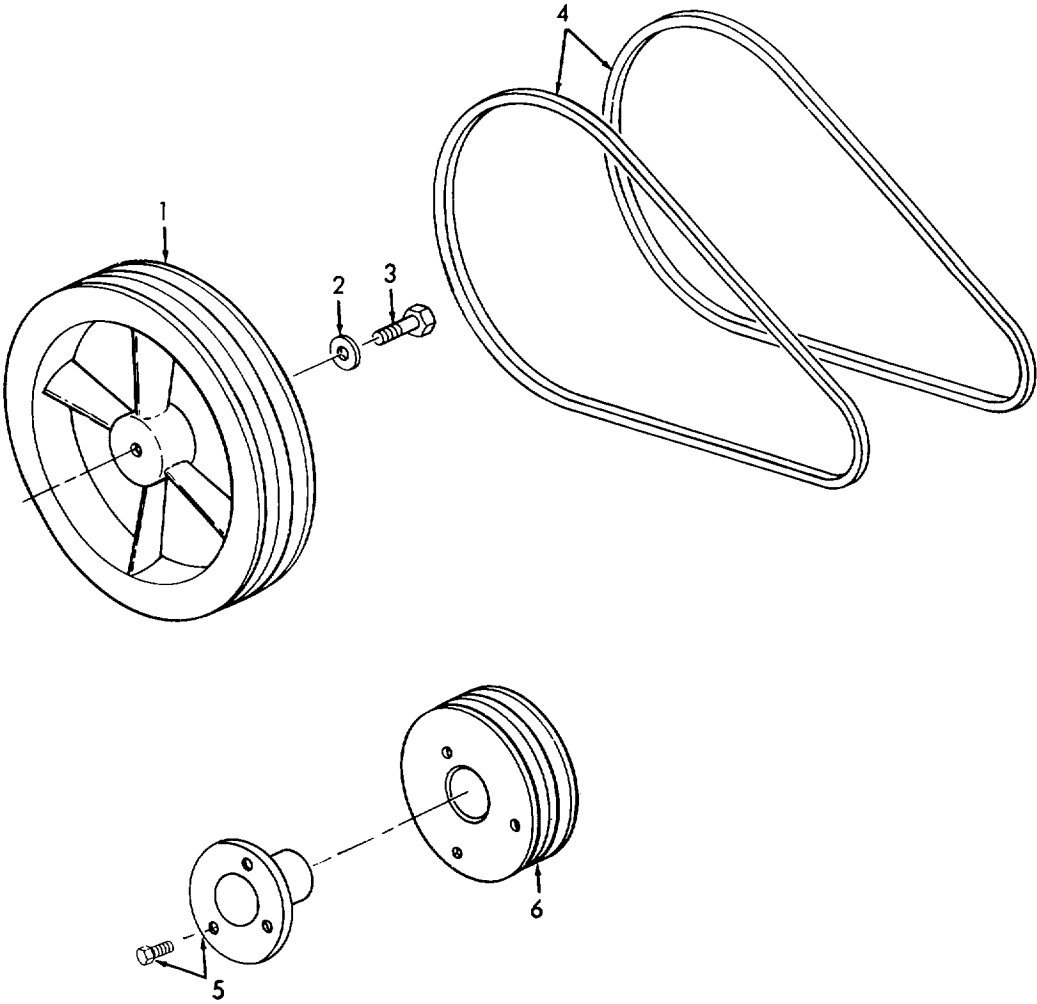

Figure 4. Matched V Belts Set and Drive Pulleys

SECTION II

TM 5-4310-377-23P

(1) ITEM NO	(2) SMR CODE	(3) FSCM	(4) PART NUMBER	(5) DESCRIPTION AND USABLE ON CODE (UOC)	(6) QTY
				GROUP 02 COMPRESSOR DRIVE	
				FIG. 4 MATCHED V BELTS SET AND DRIVE PULLEYS	
1	XBOZZ	55921	C70132-76010	PULLEY, COMPRESSOR.....	1
2	PAOZZ	55921	C70112-76210	WASHER, FINISHING.....	1
3	PAOZZ	55921	C91505-1308025	SCREW, CAP, HEXAGON.....	1
4	PAOZZ	96906	MS51065-48-2	BELTS, V, MATCHED SET, GRADE A STANDARD DUTY, .380 WIDE X .5116 IN THICK X 48 IN EFF L 2 BELTS.....	1
5	PBOZZ	76241	JAX7/8	BUSHING, TAPERED WITH 3 EA 10-24 X 7/8 HEXAGON HEAD, CAP SCREWS, GR 5.....	1
6	PBOZZ	55921	OFC233	PULLEY, GROOVE.....	1
				END OF FIGURE	

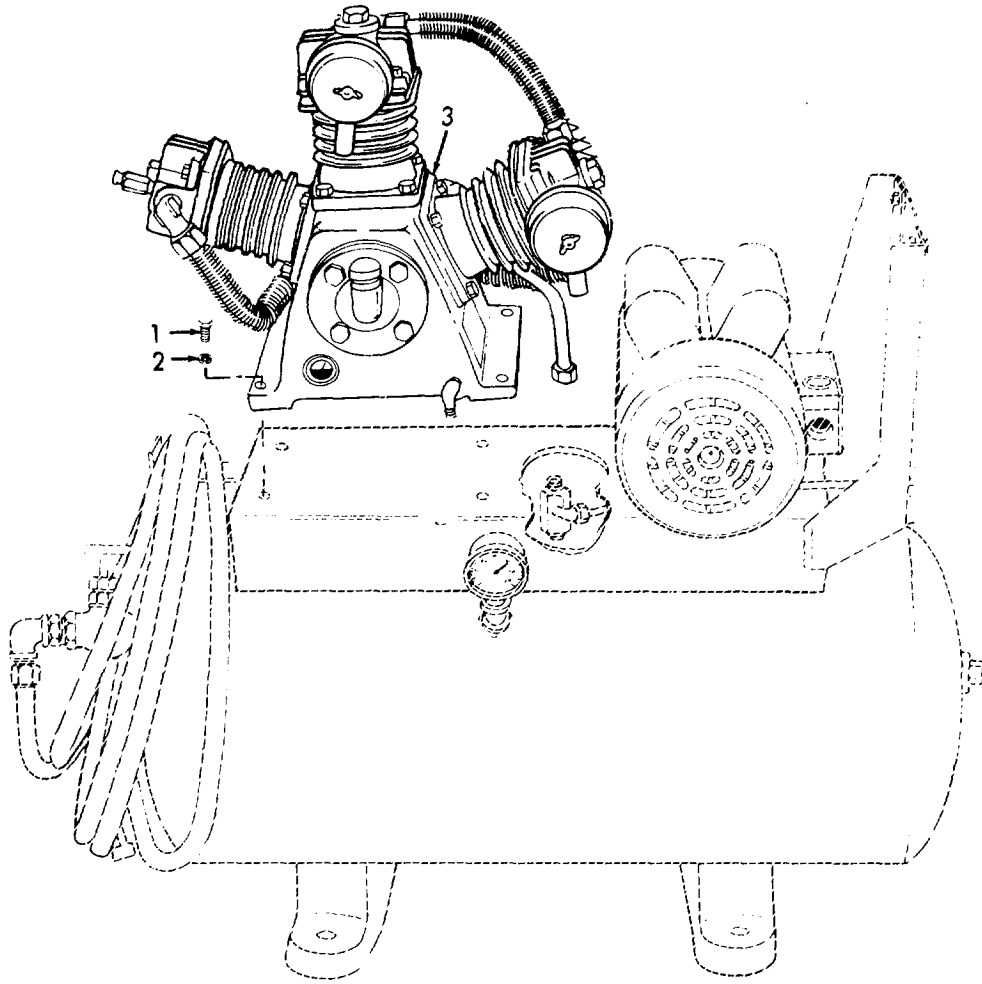

Figure 5. Compressor Mounting

SECTION II

TM 5-4310-377-23P

(1) ITEM NO	(2) SMR CODE	(3) FSCM	(4) PART NUMBER	(5) DESCRIPTION AND USABLE ON CODE (UOC)	(6) QTY
				GROUP 03 COMPRESSOR ASSEMBLY	
				FIG. 5 COMPRESSOR MOUNTING	
1	PAOZZ	96906	MS90728-34	BOLT, MACHINE, COMPRESSOR MTG 5/16 18 X 1 IN.....	4
2	PAOZZ	96906	MS35338-45	WASHER, LOCK, COMPRESSOR MTG 5/16 IN	4
3	XBOFH	55921	C50172-00000	COMPRESSOR ASSEMBLY	1
				END OF FIGURE	

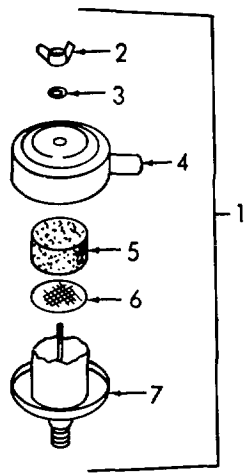

Figure 6. Air Cleaner

SECTION II

TM 5-4310-377-23P

(1) ITEM NO	(2) SMR CODE	(3) FSCM	(4) PART NUMBER	(5) DESCRIPTION AND USABLE ON CODE (UOC)	(6) QTY
				GROUP 03 COMPRESSOR ASSEMBLY	
				FIG. 6 AIR CLEANER	
1	PBOZZ	55921	C70111-66000	..STRAINER, ASSEMBLY, AIR.....	2
2	PAOZZ	55921	C92513-150400	..NUT, PLAIN, WING, M4 X .70 TH.....	1
3	PAOZZ	55921	C92521-150400	..WASHER, FLAT, 4 MM ID X 10 MM OD.....	1
4	XAOZZ	55921	C70111-66170	..COVER, AIR STRAINER.....	1
5	PAOZZ	55921	C70111-66140	..FILTER ELEMENT, INTAKE.....	1
6	PAOZZ	55921	C70111-66110	..WIRE SCREEN STRAINER, 24 X 3/16 IN.....	1
7	XAOZZ	55921	C70111-66010	..BODY, AIR STRAINER.....	1
				END OF FIGURE	

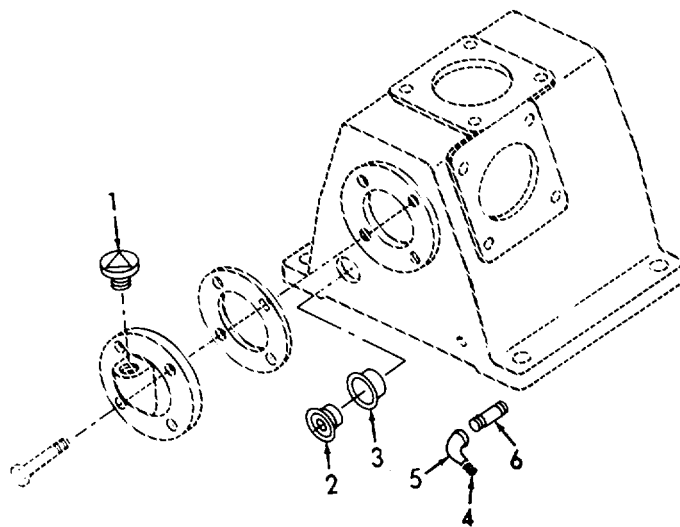

Figure 7. Oil Filler, Cap, and Plugs

SECTION II

TM 5-4310-377-23P

(1) ITEM NO	(2) SMR CODE	(3) FSCM	(4) PART NUMBER	(5) DESCRIPTION AND USABLE ON CODE (UOC)	(6) QTY
				GROUP 03 COMPRESSOR ASSEMBLY	
				FIG. 7 OIL FILLER, CAP, AND PLUG	
1	XBOZZ	55921	C70111-57610	.CAP, BREATHER.....	1
2	XBOZZ	55921	C70111-57700	.COVER ASSEMBLY, GAUGE	1
3	PAOZZ	55921	C70111-57730	.PACKING, PREFORMED, ASTM NBR SYNTHETIC RUBBER.....	1
4	PAOZZ	96906	MS51884-3	.PLUG, PIPE, 1/4 IN NPT.....	1
5	PAOZZ	93236	PL12M	ELBOW, PIPE, 1/4 IN FPT X 90 DEG	1
6	PAOZZ	96906	MS51953-29	NIPPLE, PIPE, 1/4 IN X 1 1/2 IN NPT.....	1
				END OF FIGURE	

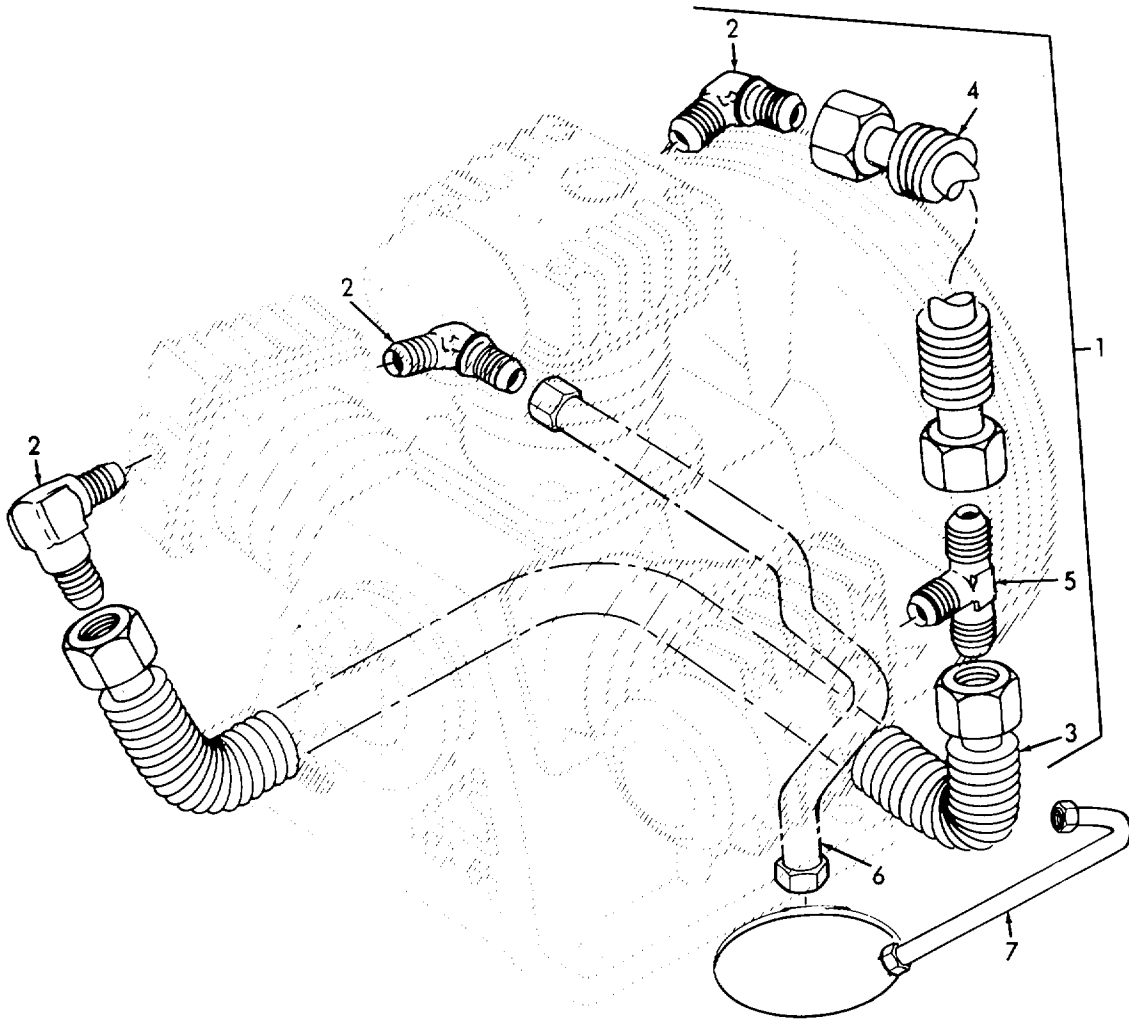

Figure 8. Tube Assemblies

SECTION II

TM 5-4310-377-23P

(1) ITEM NO	(2) SMR CODE	(3) FSCM	(4) PART NUMBER	(5) DESCRIPTION AND USABLE ON CODE (UOC)	(6) QTY
				GROUP 03 COMPRESSOR ASSEMBLY	
				FIG. 8 TUBE ASSEMBLIES	
1	XCOZZ	55921	C70172-87300	.PIPING ASSEMBLY	1
2	PAOZZ	55921	C70122-87010	..ELBOW, PIPE TO TUBE	3
3	PAOZZ	55921	C70172-87100	..PIPING ASSEMBLY	1
4	PAOZZ	55921	C70132-87100	..PIPING ASSEMBLY	1
5	PAOZZ	55921	C70132-87030	..TEE, PIPE TO TUBE	1
6	XBOOO	55921	0FB875	.TUBE ASSEMBLY, DISCHARGE, 1/2 IN COPPER SOFT TYPE L W/FLARE NUT, COMPR NUT & SLEEVE.....	1
7	XBOOO	55921	VA1602	.TUBE ASSEMBLY, UNLOADER, 1/4 IN OD 22 ¹ / ₂ IN LONG	1
				END OF FIGURE	

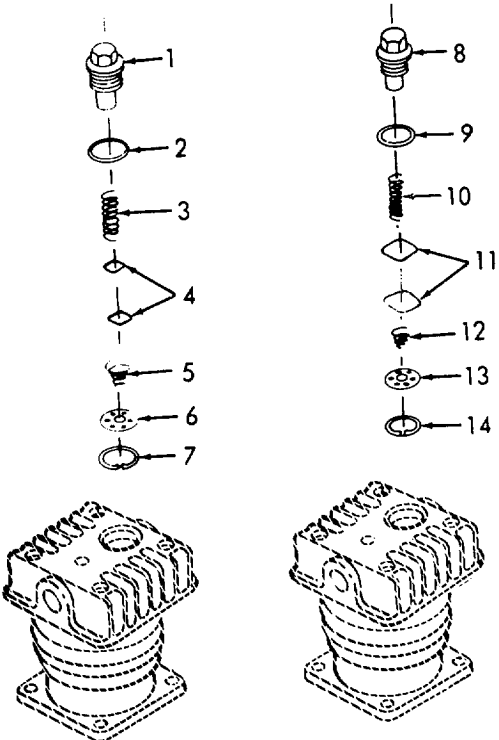

Figure 9. Intake and Exhaust Valves

SECTION II

TM 5-4310-377-23P

(1) ITEM NO	(2) SMR CODE	(3) FSCM	(4) PART NUMBER	(5) DESCRIPTION AND USABLE ON CODE (UOC)	(6) QTY
GROUP 03 COMPRESSOR ASSEMBLY					
FIG. 9 INTAKE AND EXHAUST VALVES					
1	XBOZZ	55921	C70111-11450	.COVER, OUTLET VALVE PUSHER, 2ND STAGE	1
2	PAOZZ	55921	C70111-11460	.PACKING PREFORMED	1
3	PAOZZ	55921	C70172-42070	.SPRING, HELICAL COMPR OUTLET VALVE, 2ND STAGE	1
4	PAOZZ	55921	C70111-31030	.PLATE, VALVE, INLET/OUTLET, 2ND STAGE	2
5	PAOZZ	55921	C70172-32070	.SPRING, HELICAL COMP INLET, 2ND STAGE	1
6	PAOZZ	55921	C70111-31020	.RECEIVER, VALVE INLET, 2ND STAGE	1
7	PAOZZ	79136	10-100-0240	.CLIP, RETAINING INLET VALVE, 2ND STAGE	1
8	XBOZZ	55921	C70112-11450	.COVER, PUSH, OUTLET VALVE, 1ST STAGE	2
9	PAOZZ	55921	C70112-11460	.PACKING, PREFORMED, OUTLET VALVE, 1ST STAGE	2
10	PAOZZ	55921	C70112-41070	.SPRING, HELICAL COMP, 1ST STAGE	2
11	PAOZZ	55921	C70112-31030	.PLATE, VALVE, 1ST STAGE, INLET/OUTLET	4
12	PAOZZ	55921	C70112-31070	.SPRING, HELICAL COMP, 1ST STAGE	2
13	PAOZZ	55921	C70112-31020	.RECEIVER, VALVE INLET 1ST STAGE	2
14	PAOZZ	79136	10-100-0300	.CLIP, RETAINING, 1ST STAGE	2
END OF FIGURE					

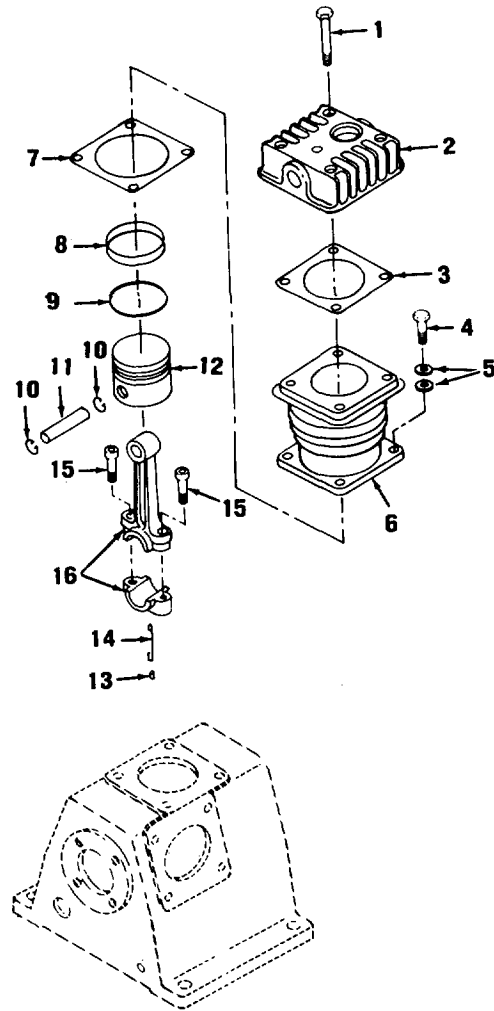

Figure 10. First Stage Piston, Connecting Rod, and Cylinder Block

SECTION II

TM 5-4310-377-23P

(1) ITEM NO	(2) SMR CODE	(3) FSCM	(4) PART NUMBER	(5) DESCRIPTION AND USABLE ON CODE (UOC)	(6) QTY
				GROUP 03 COMPRESSOR ASSEMBLY	
				FIG. 10 FIRST STAGE PISTON, CONNECTING ROD, AND CYLINDER BLOCK	
1	PAFZZ	55921	C91505-1308025	.SCREW, CAP, HEXAGON, 1ST STAGE	4
2	XBFZZ	55921	C70112-11010	.HEAD, CYLINDER, 1ST STAGE	2
3	PAFZZ	55921	C70112-11020	.GASKET, 1ST STAGE ASBESTOS, NO. 1500	2
4	PAFZZ	55921	C91501-1308020	.SCREW, CAP, HEXAGON, M8 X 1.25 THD X 20 MM LONG, 1ST STAGE	4
6	XBFZZ	55921	C70112-51010	.CYLINDER, 1ST STAGE	2
7	PAFZZ	55921	C70112-51030	.GASKET, ASBESTOS NO. 1500, 1ST STAGE	1
8	PAFZZ	55921	C70112-61030	.RING, PISTON, 1ST STAGE	4
9	PAFZZ	55921	C70112-61050	.RING, PISTON, 1ST STAGE	2
10	PAFZZ	55921	C70112-61070	.RING, RETAINING, 1ST STAGE	2
11	PBFZZ	55921	C70112-61120	.PIN, PISTON, 1ST STAGE	2
12	PBFZZ	55921	C70112-61010	.PISTON, COMPRESSOR, 1ST STAGE	2
13	XBFZZ	55921	C91505-2304010	.BOLT, MACHINE, M4 X .70 THD 10 MM LONG CADIUM PLATED, 1ST STAGE	1
14	XBFZZ	55921	C70122-61280	DIPPER, OIL SPLASH, 1ST STAGE	1
15	PAFZZ	55921	C70112-61250	.BOLT, CONNECTING ROD, 1ST STAGE	2
16	XBFZZ	55921	C70112-61210	.ROD ASSEMBLY, CONNECTING, 1ST STAGE	1
				END OF FIGURE	

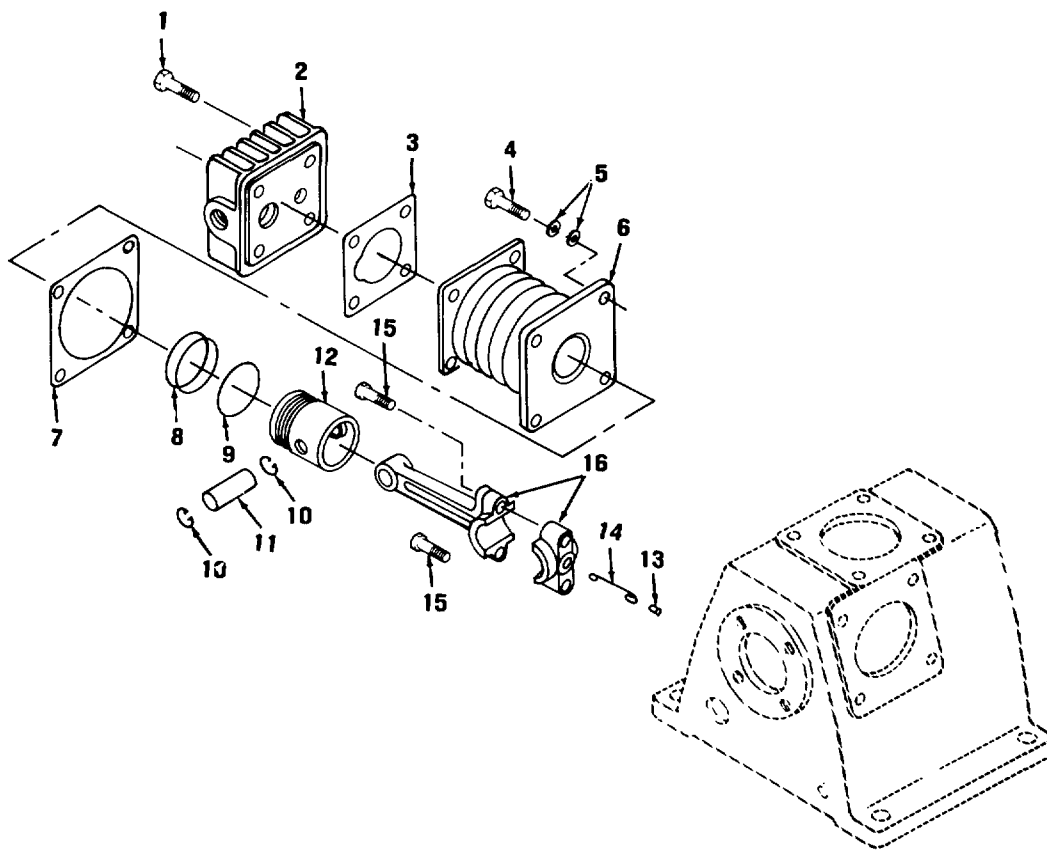

Figure 11. Second Stage Piston, Connecting Rod, and Cylinder Block

SECTION II

TM 5-4310-377-23P

(1) ITEM NO	(2) SMR CODE	(3) FSCM	(4) PART NUMBER	(5) DESCRIPTION AND USABLE ON CODE (UOC)	(6) QTY
				GROUP 03 COMPRESSOR ASSEMBLY	
				FIG. 11 SECOND STAGE PISTON, CONNECTING ROD, AND CYLINDER BLOCK	
1	PAFZZ	55921	C91505-1308025	.SCREW, CAP, HEXAGON, 2ND STAGE	8
2	XBFZZ	55921	C70172-12010	.HEAD, CYLINDER, 2ND STAGE	1
3	PAFZZ	55921	C70111-11020	.GASKET, ASBESTOS NO. 1500, 2ND STAGE	1
4	PAFZZ	55921	C91501-1308020	.SCREW, CAP, HEXAGON, 2ND STAGE	8
6	XBFZZ	55921	C70172-52010	.CYLINDER, 2ND STAGE	1
7	PAFZZ	55921	C70112-51030	.GASKET, ASBESTOS NO. 1500	2
8	PAFZZ	55921	C70111-61030	.RING, PISTON, 2ND STAGE	2
9	PAFZZ	55921	C70111-61050	.RING, PISTON, 2ND STAGE	2
10	PAFZZ	55921	C70112-61070	.RING, RETAINING, 2ND STAGE	4
11	PBFZZ	55921	C70172-62120	.PIN, PISTON, 2ND STAGE	1
12	PBFZZ	55921	C70172-62010	.PISTON, COMPRESSOR, 2ND STAGE	1
13	PAFZZ	55921	C91505-2304010	.BOLT, MACHINE, M4 X .70 THD 10 MM LONG CADIUM PLATED, 2ND STAGE	2
14	XBFZZ	55921	C70122-61280	.DIPPER, OIL SPLASH, 2ND STAGE	2
15	PAFZZ	55921	C70112-61250	.BOLT, CONNECTING ROD, 2ND STAGE	
16	XBFZZ	55921	C70112-61210	.ROD ASSEMBLY CONNECTING	2
				END OF FIGURE	

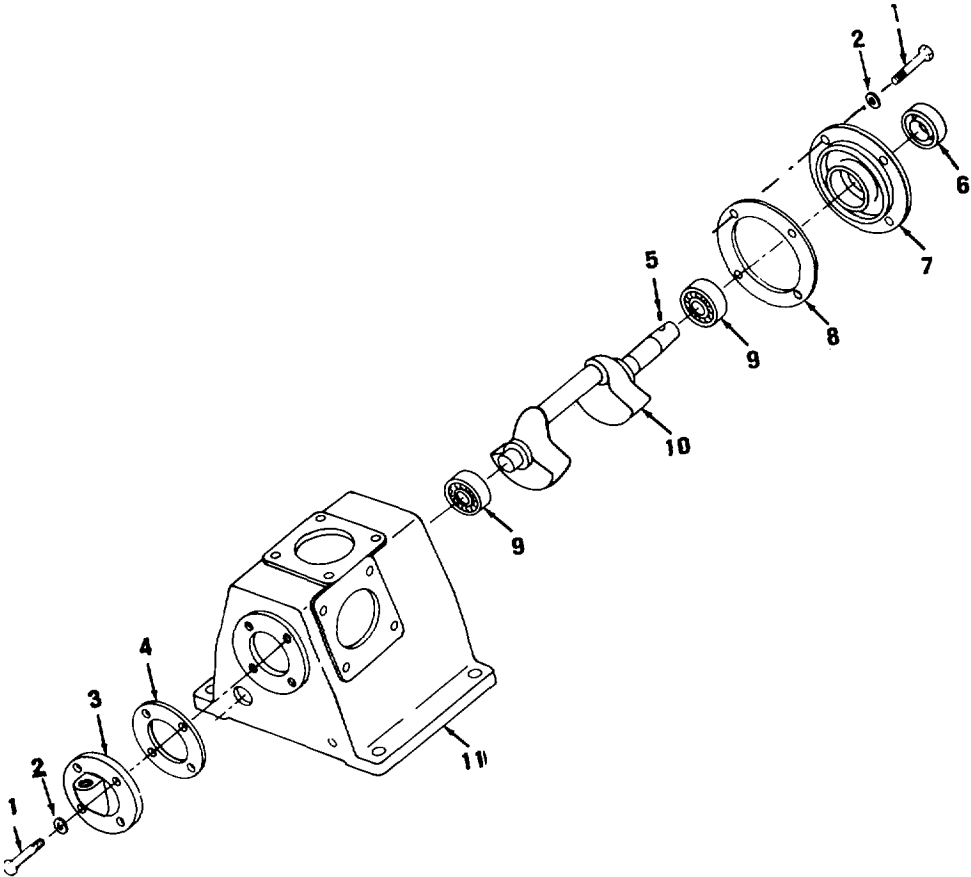

Figure 12. Crankshaft, Bearing, and Oil Seals

SECTION II

TM 5-4310-377-23P

(1) ITEM NO	(2) SMR CODE	(3) FSCM	(4) PART NUMBER	(5) DESCRIPTION AND USABLE ON CODE (UOC)	(6) QTY
				GROUP 03 COMPRESSOR ASSEMBLY	
				FIG. 12 CRANKSHAFT, BEARING, AND OIL SEALS	
1	PAFZZ	55921	C91501-1308020	.SCREW, CAP, HEXAGON, FRONT AND REAR COVER MTG, M8 X 1.25 THD X 20 MM LONG	8
2	XBFZZ	55921	C70122-57060	.COVER, BEARING, REAR.....	1
4	PAFZZ	55921	C70122-57070	.GASKET, ASBESTOS NO. 1500	1
5	PAFZZ	55921	C70112-56060	.PIN, STRAIGHT, HEADLESS	1
6	PAFZZ	55921	C70122-57080	.SEAL, PLAIN ENCASED	1
7	XBFZZ	55921	C70122-57030	.COVER, BEARING, FRONT	1
8	PAFZZ	55921	C70122-57040	.GASKET, FRONT COVER ASBESTOS NO. 1500	1
9	PAFZZ	21335	205K	.BEARING, BALL, ANNULAR.....	2
10	XBFZZ	55921	C70132-56010	.CRANKSHAFT.....	1
11	XBFZZ	55921	C70132-57010	.CRANKCASE	1
				END OF FIGURE	

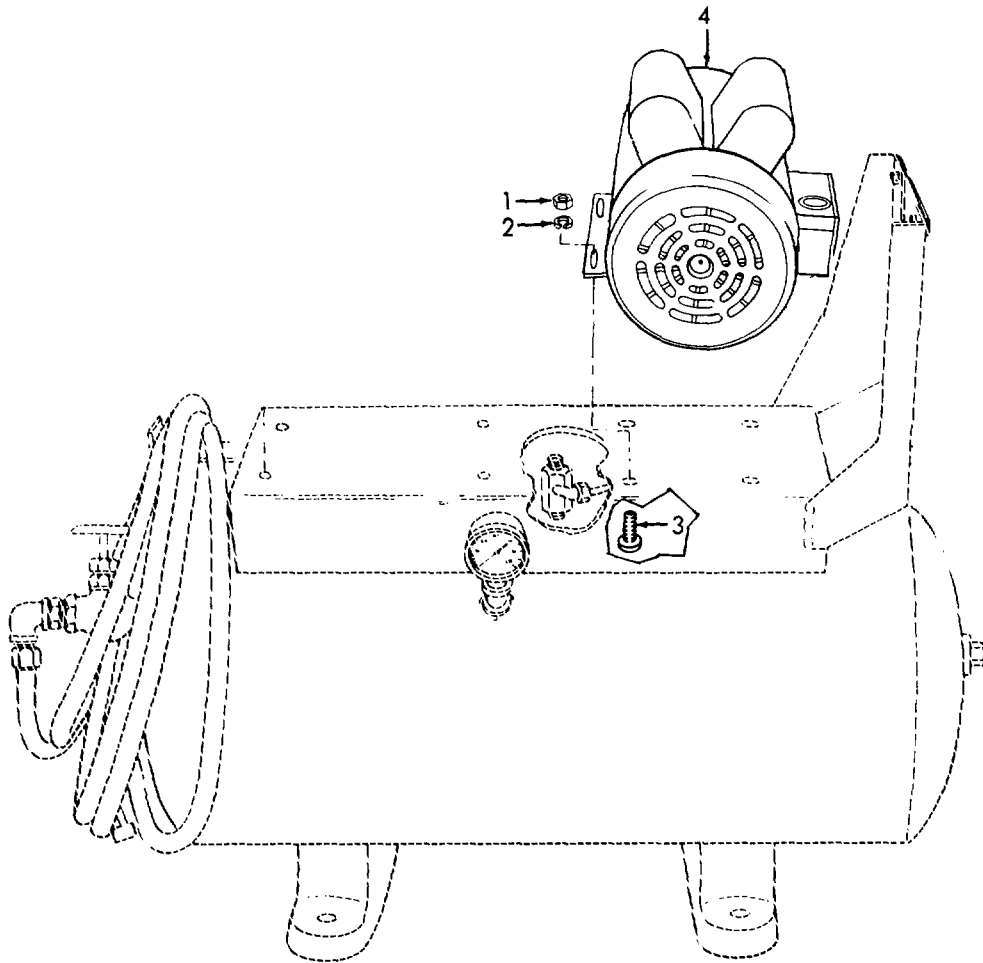

Figure 13. Electric Motor Mounting

SECTION II

TM 5-4310-377-23P

(1) ITEM NO	(2) SMR CODE	(3) FSCM	(4) PART NUMBER	(5) DESCRIPTION AND USABLE ON CODE (UOC)	(6) QTY
				GROUP 04 ELECTRIC MOTOR	
				FIG. 13 ELECTRIC MOTOR MOUNTING	
1	PAOZZ	96906	MS35649-2312	NUT, PLAIN, HEXAGON, MOTOR MTG 5/16-18 CARBON STEEL	4
2	PAOZZ	96906	MS35338-45	WASHER, LOCK, MOTOR MTG, STEEL CARBON 5/16 IN	4
3	PAOZZ	96906	MS35751-41	BOLT, SQUARE NECK, MOTOR MTG, 5/16-18 X 1 IN LONG STEEL	4
4	PBOOF	92940	606331	MOTOR, ALTERNATING C, 2 HP, 1PH, 115V, 60 HZ ..	1
				END OF FIGURE	

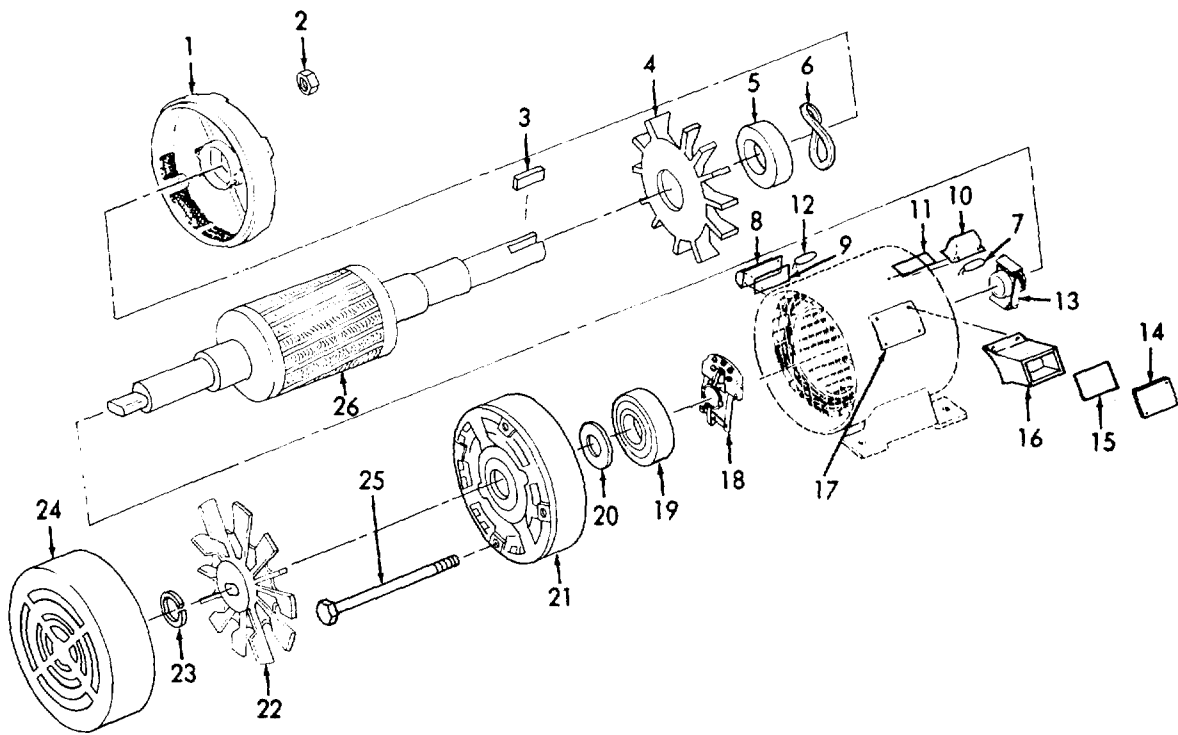

Figure 14. Electric Motor

SECTION II

TM 5-4310-377-23P

(1) ITEM NO	(2) SMR CODE	(3) FSCM	(4) PART NUMBER	(5) DESCRIPTION AND USABLE ON CODE (UOC)	(6) QTY
				GROUP 04 ELECTRIC MOTOR	
				FIG. 14 ELECTRIC MOTOR	
*	1	XAOZZ	92940	93C304673501	.END SHIELD, SHAFT END 1
	2	PAOZZ	96906	MS25082-3	.NUT, SELF-LOCKING, 10-32 4
	3	PBOZZ	92940	23A02741900	.KEY, MACHINE, 3/16 IN X 3/16 In X 2 IN 1
	4	XBOZZ	92940	12A045940300	.FAN..... 1
	5	PAOZZ	92940	04A091010400	.BEARING, BALL, ANNULAR 1
	6	XBOZZ	92940	22A022920300	.WASHER, SPRING WAVY 1
	7	PAOZZ	92940	15A088402200	.CAPACITOR, FIXED, PLAIN 1
	8	XBOZZ	92940	16B045990100	.COVER, CAPACITOR..... 1
	9	XBOZZ	92940	29A093280100	.GASKET 1
	10	XBOZZ	92940	16B037370100	.COVER, CAPACITOR, RUN 1
	11	XBOZZ	92940	29A093290100	.GASKET 1
	12	PAOZZ	92940	93A120018002	.CAPACITOR, RUN, 16 MFD 240 VAC 1
	13	PBOZZ	92940	93C305766003	.SWITCH, CENTRIFUGAL 1
	14	XBOZZ	92940	93A120387001	.COVER, CONDUIT BOX 1
	15	XBOZZ	92940	93A120118003	.GASKET, COVER..... 1
	16	XBOZZ	92940	93B208465001	.BOX, CONDUIT 1
	17	XBOZZ	92940	29A082870100	.GASKET, BOX..... 1
	18	PBOZZ	92940	93A113114100	.CONTACT, ELECTRICAL..... 1
	19	PAOZZ	92940	04A091010200	.BEARING, BALL, ANNULAR..... 1
	20	XBOZZ	92940	28A093170100	.SPACER..... 1
	21	XBOZZ	92940	07C034710303	.END SHIELD 1
	22	XBOZZ	92940	12B037260100	.FAN, EXTERNAL 1
	23	XBOZZ	92940	24A092850300	.RING, LOCKING..... 1
	24	XBOZZ	92940	11B037270100	.GUARD, FAN 1
	25	XBOZZ	92940	19A012543200	.BOLT, THRU 10-32X10 ³ / ₈ IN 4
	26	XAOZZ	92940	93B240681006	.ROTOR ASSEMBLY 1
				END OF FIGURE	

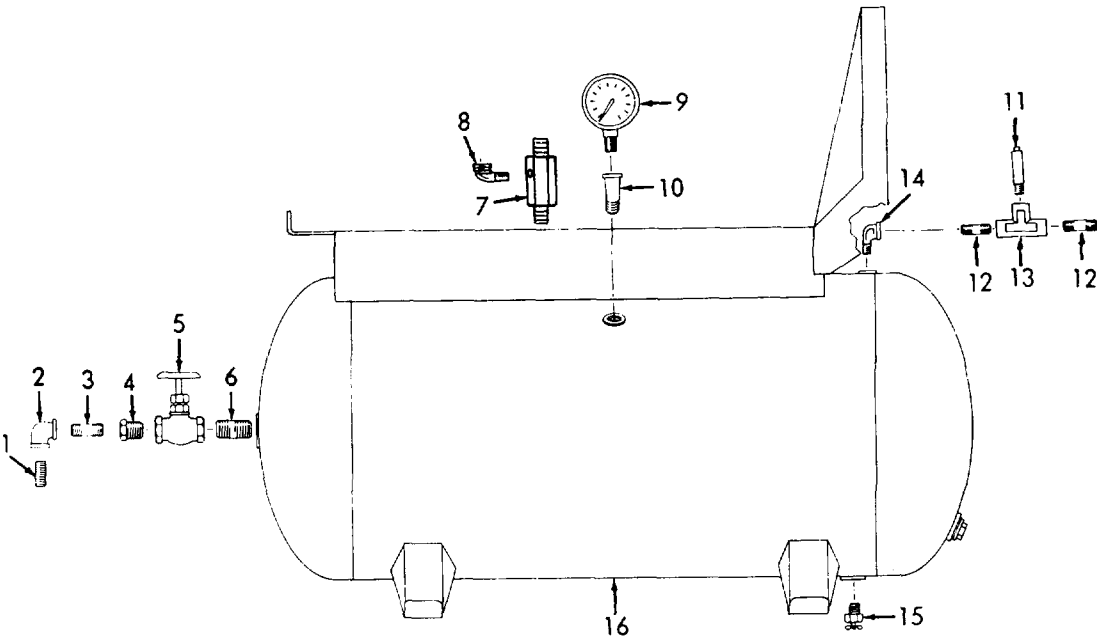

Figure 15. Air Receiver System

SECTION II

TM 5-4310-377-23P

(1) ITEM NO	(2) SMR CODE	(3) FSCM	(4) PART NUMBER	(5) DESCRIPTION AND USABLE ON CODE (UOC)	(6) QTY
GROUP 05 AIR RECEIVER SYSTEM					
FIG. 15 AIR RECEIVER SYSTEM					
1	PAOZZ	96906	MS51953-29	NIPPLE, PIPE 1/4 X 1 1/2 IN NPT	1
2	PAOZZ	92679	144127	ELBOW, PIPE, 1/4 IN 90 DEG GALVANIZED	1
3	PAOZZ	96906	MS51953-25	NIPPLE, PIPE, 1/4 X 7/8 IN	1
4	PAOZZ	96906	MS51887-9	BUSHING, PIPE, 1/2 IN X 1/4 IN	1
5	PAOZZ	86107	592-14	VALVE, GLOBE, 1/2 IN NPT BRASS	1
6	PAOZZ	96906	MS51953-73	NIPPLE, PIPE, 1/2 X 1 1/8 IN	1
7	PAOZZ	58818	C5050	VALVE, CHECK, 1/2 IN OD TUBE INLET X 1/2 IN MPT OUTLET WITH 1/8 IN SIDE PORT, BR	1
8	PAOZZ	79470	69X4	ELBOW, PIPE TO TUBE, 1/8 IN MPT X 1/4 IN OD TUBE, BRASS	1
9	PAOZZ	61349	046778	GAGE, PRESSURE, DIAL, 1/4 IN MPT BOTTOM CONNECTION 2 IN DIA. 0-300 PSI	1
10	PAOZZ	96906	MS39231-2	ELBOW, PIPE 1/4 IN 45 DEG. STREET	1
11	XBOZZ	58818	SV-33-3/8-200	VALVE, RELIEF, 3/8 IN MPT-200 PSI, BRASS	1
12	PAOZZ	96906	MS51953-52	NIPPLE, PIPE, 3/8 X 1 1/2 IN.....	2
13	PAOZZ	72423	1021-060	TEE, PIPE, 3/8 IN	1
14	PAOZZ	96906	MS39230-3	ELBOW, PIPE, 3/8 IN 90 DEG. STREET	1
15	PAOZZ	96906	MS25782-5	COCK, DRAIN, 1/4 IN MPT, BRASS	1
16	XBOZZ	55921	OFC232	TANK ASSEMBLY, COMP	1
END OF FIGURE					

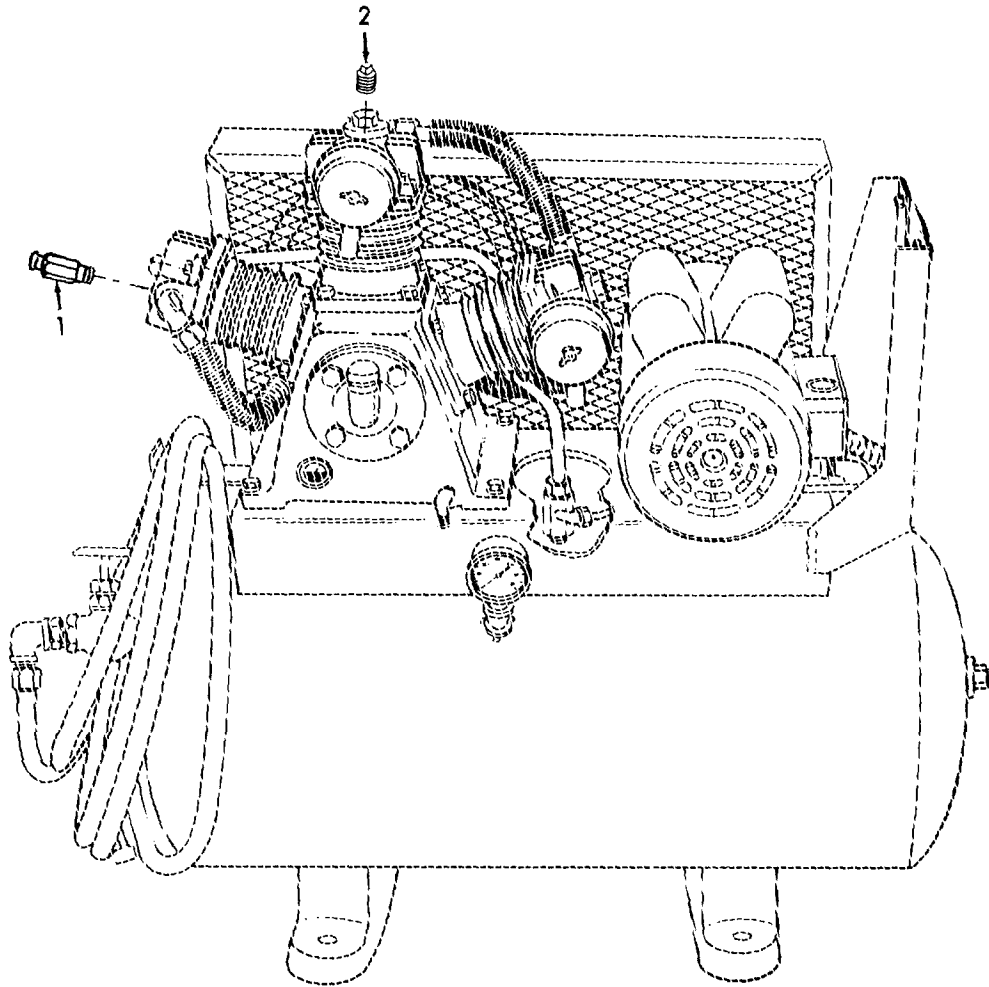

Figure 16. Relief Valve and Plug

SECTION II

TM 5-4310-377-23P

(1) ITEM NO	(2) SMR CODE	(3) FSCM	(4) PART NUMBER	(5) DESCRIPTION AND USABLE ON CODE (UOC)	(6) QTY
				GROUP 05 AIR RECEIVER SYSTEM	
				FIG. 16 RELIEF VALVE AND PLUG	
1	PAOZZ	58818	NC25-70	VALVE, SAFETY RELIEF, 1/4 IN MPT-70PSIG, BRASS	1
2	PAOZZ	96906	MS51884-3	PLUG, PIPE, 1/4 MPT STEEL	2
				END OF FIGURE	

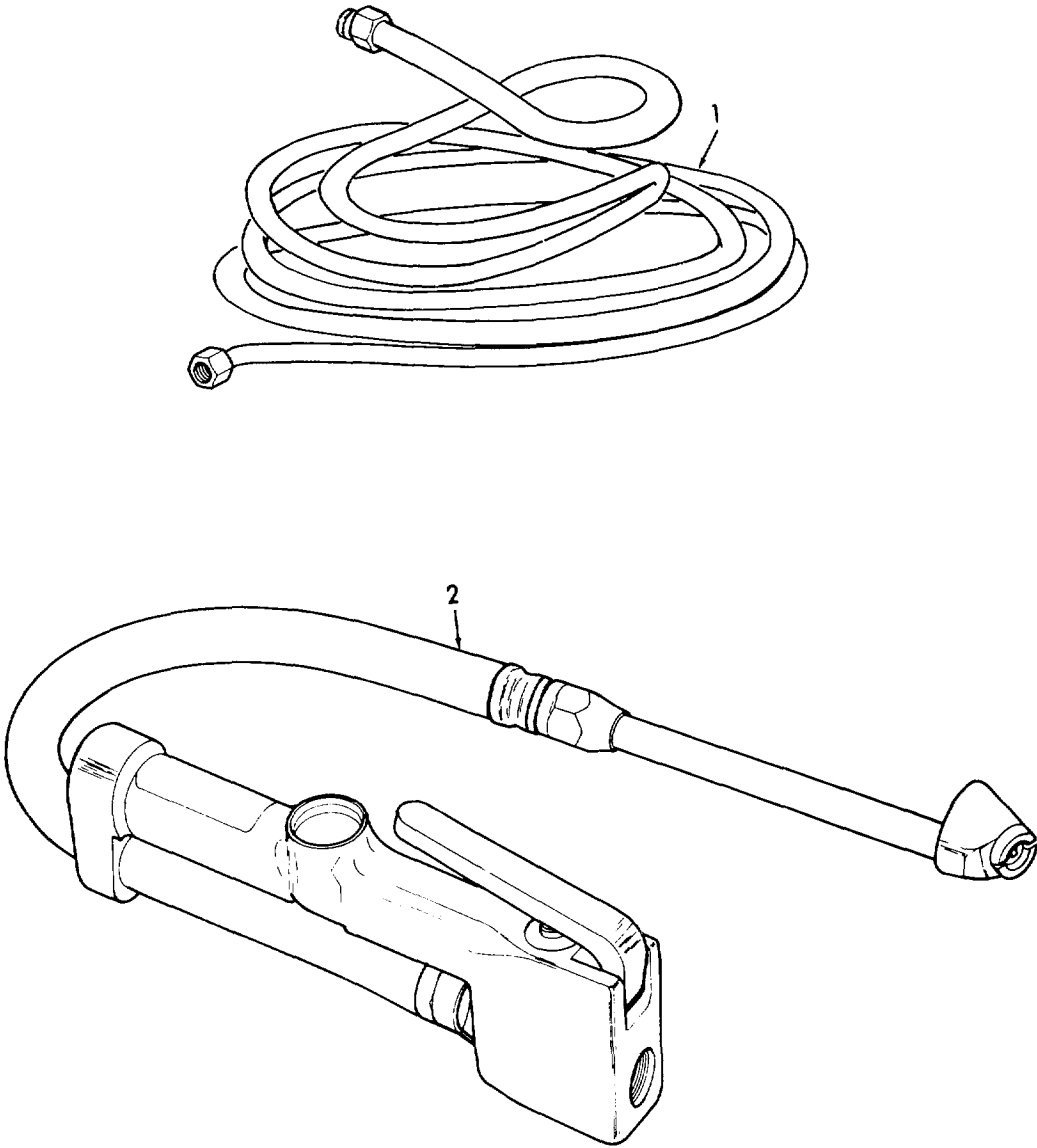

Figure 17. Air Discharge System

SECTION II

TM 5-4310-377-23P

(1) ITEM NO	(2) SMR CODE	(3) FSCM	(4) PART NUMBER	(5) DESCRIPTION AND USABLE ON CODE (UOC)	(6) QTY
				GROUP 06 AIR DISCHARGE SYSTEM	
				FIG. 17 AIR DISCHARGE SYSTEM	
1	PAOZZ	55921	VR318	HOSE ASSEMBLY, NONMETALLIC 5/16 IN ID X 50 FEET LONG	1
2	PAOZZ	81348	GG-G-91	INFLATOR-GAGE, PNEUMATIC.....	1
				END OF FIGURE	

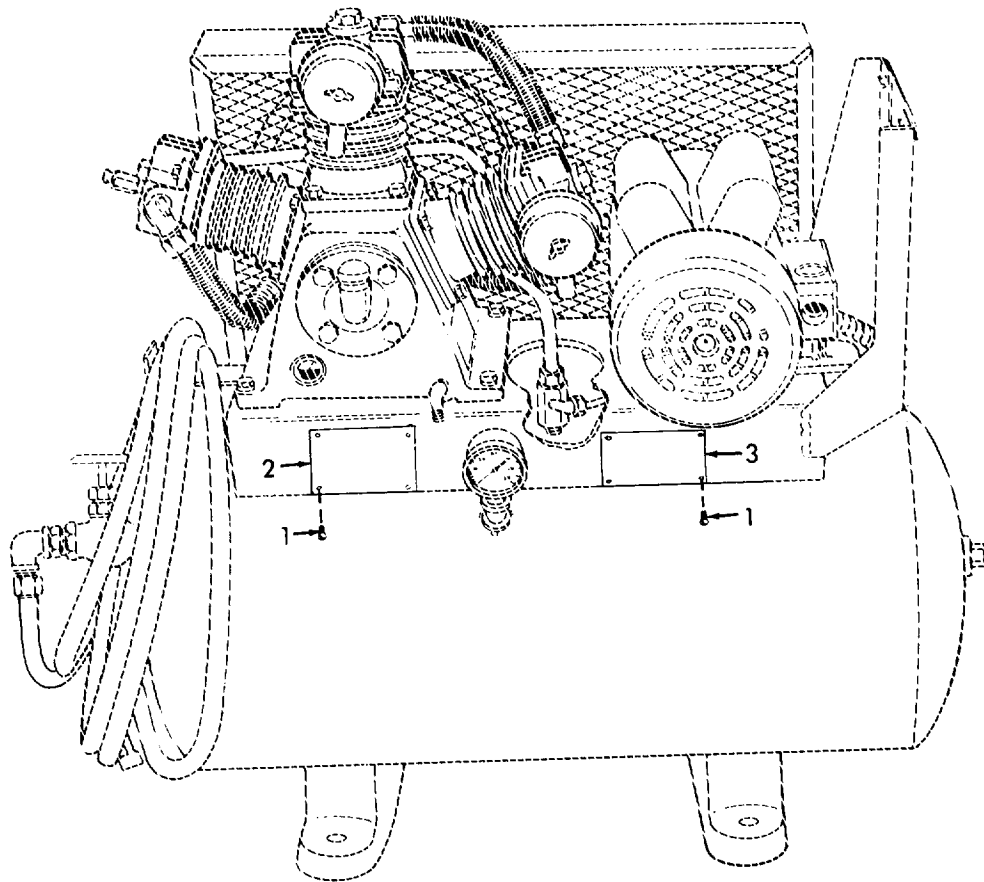

Figure 18. Data Plates

SECTION II

TM 5-4310-377-23P

(1) ITEM NO	(2) SMR CODE	(3) FSCM	(4) PART NUMBER	(5) DESCRIPTION AND USABLE ON CODE (UOC)	(6) QTY
				GROUP 07 DATA PLATES	
				FIG. 18 DATA PLATES	
1	PAOZZ	96906	MS51861-22	SCREW, TAPPING, THREAD IDENTIFICATION PLATE MTG NO. 6 X 1/4 IN	8
2	XCOZZ	55921	QA-6-9-83	PLATE, IDENTIFICATION	1
3	XCOOZ	55921	QA-6-8-83	PLATE, INFORMATION.....	1
				END OF FIGURE	

SECTION II

TM 5-4310-377-23P

(1) ITEM NO	(2) SMR CODE	(3) FSCM	(4) PART NUMBER	(5) DESCRIPTION AND USABLE ON CODE (UOC)	(6) QTY
1	PAOZZ	95535	55229	<p>GROUP 08 BULK</p> <p>FIG. BULK</p> <p>TUBE, METALLIC, 1/2 IN COPPER SOFT TYPE L .032 IN WALL THICKNESS</p> <p>END OF FIGURE</p>	1

BULK-1

Section III. SPECIAL TOOLS LIST

(Not Applicable)

NATIONAL STOCK NUMBER AND PART NUMBER INDEX					
NATIONAL STOCK NUMBER INDEX					
STOCK NUMBER	FIG.	ITEM	STOCK NUMBER	FIG.	ITEM
5305-00-068-0508	1	7	4310-01-184-7536	10	8
	3	6	4310-01-184-7537	10	9
5975-00-152-1122	1	6	4310-01-184-7538	11	8
4310-00-165-0579	16	1	4310-01-195-7877	11	9
4730-00-187-4207	7	4	5945-01-203-6719	1	13
	16	2	5950-01-203-8496	1	14
4730-00-196-1465	15	3	5970-01-204-4641	1	3
4730-00-196-1502	7	6	4310-01-204-5242	11	11
	15	1	4310-01-204-5260	9	6
4730-00-204-3481	15	4	4310-01-204-5261	9	11
5975-00-208-5413	1	17	4310-01-204-5262	9	13
5306-00-226-4825	3	11	4310-01-204-5301	10	12
5306-00-226-4827	5	1	4710-01-204-5311	8	4
5975-00-243-4491	1	2	4310-01-204-7890	6	5
4730-00-249-2030	15	13	4820-01-204-7927	15	7
4730-00-249-3915	7	5	4730-01-204-7945	8	5
4730-00-253-4413	15	14	3020-01-204-8133	4	6
6685-00-264-3961	15	9	4720-01-204-8374	17	1
4730-00-278-4284	15	2	4310-01-204-8406	10	11
4730-00-278-4290	15	10	4310-01-204-8434	9	4
4730-00-287-1766	15	8	4730-01-204-8481	6	6
5975-00-296-0534	1	18	5999-01-205-2039	14	18
4820-00-403-4658	15	5	4310-01-205-9492	11	12
5310-00-407-9566	3	10	4730-01-206-3546	8	2
	5	2	5306-01-207-7529	10	15
	13	2		11	15
4710-00-424-2694	BULK	1	5306-01-207-9308	4	3
5305-00-432-8027	18	1		10	1
5310-00-455-2833	3	8		11	1
5930-00-521-8471	2		5330-01-207-9375	12	6
4910-00-522-3778	17	2	5330-01-207-9422	12	4
3110-00-533-9592	14	19	5330-01-207-9423	12	8
5930-00-539-2108	2	1	5330-01-207-9428	7	3
3110-00-554-5403	12	9	5310-01-208-0289	6	3
5310-00-582-5965	1	9	5330-01-208-1979	9	9
	3	3	5330-01-208-1980	10	7
5975-00-681-0531	1	24		11	7
5306-00-721-5944	13	3	5310-01-208-2898	6	2
5310-00-761-6882	1	8	5305-01-208-5210	11	13
	3	2	5360-01-208-5660	9	12
4730-00-761-8538	15	12	5310-01-208-6733	4	2
5310-00-829-9981	13	1	5365-01-208-6926	9	14
4820-00-849-1220	15	15	5365-01-208-6927	10	10
5310-00-880-7744	3	9		11	10
4730-00-921-3612	15	6	5365-01-208-6941	4	5
3030-00-983-2873	4	4	5330-01-209-7301	11	3
5305-00-984-6208	3	7	5360-01-209-7612	9	3
5970-01-087-7328	1	21	5360-01-209-7613	9	10
3110-01-172-1795	14	5	5365-01-209-9711	9	7
6105-01-182-8872	13	4			

*

NATIONAL STOCK NUMBER AND PART NUMBER INDEX					
STOCK NUMBER	NATIONAL STOCK NUMBER INDEX		STOCK NUMBER	FIG.	ITEM
	FIG.	ITEM			
5315-01-210-6547	12	5			
5360-01-210-6554	9	5			
5330-01-210-6557	9	2			
5330-01-210-6559	10	3			
5310-01-210-6564	14	2			
5930-01-210-8734	1	11			

NATIONAL STOCK NUMBER AND PART NUMBER INDEX				
FSCM	PART NUMBER INDEX		FIG.	ITEM
	PART NUMBER	STOCK NUMBER		
88044	AN3066-8	5975-00-208-5413	1	17
55921	CAC2230		3	5
55921	CAC2231		3	14
55921	CAC2233		3	13
55921	CAC2234		3	4
55921	CAC2237		3	12
55921	CAC2238		3	1
52034	CA3-2P-23-120V + C T3-32A-M 12-H0A		1	10
52034	CA3-23		1	15
52034	CT3-32A	5945-01-203-6719	1	13
78553	C1379-1024-1	5310-00-455-2833	3	8
55921	C50172-00000		5	3
58818	C5050	4820-01-204-7927	15	7
55921	C70111-11020	5330-01-209-7301	11	3
55921	C70111-11450		9	1
55921	C70111-11460	5330-01-210-6557	9	2
55921	C70111-31020	4310-01-204-5260	9	6
55921	C70111-31030	4310-01-204-8434	9	4
55921	C70111-57610		7	1
55921	C70111-57700		7	2
55921	C70111-57730	5330-01-207-9428	7	3
55921	C70111-61030	4310-01-184-7538	11	8
55921	C70111-61050	4310-01-195-7877	11	9
55921	C70111-66000		6	1
55921	C70111-66010		6	7
55921	C70111-66110	4730-01-204-8481	6	6
55921	C70111-66140	4310-01-204-7890	6	5
55921	C70111-66170		6	4
55921	C70111-11010		10	2
55921	C70112-11020	5330-01-210-6559	10	3
55921	C70112-11450		9	8
55921	C70112-11460	5330-01-208-1979	9	9
55921	C70112-31020	4310-01-204-5262	9	13
55921	C70112-31030	4310-01-204-5261	9	11
55921	C70112-31070	5360-01-208-5660	9	12
55921	C70112-41070	5360-01-209-7613	9	10
55921	C70112-51010		10	6
55921	C70112-51030	5330-01-208-1980	10	7
			11	7
55921	C70112-56060	5315-01-210-6547	12	5
55921	C70112-61010	4310-01-204-5301	10	12
55921	C70112-61030	4310-01-184-7536	10	8
55921	C70112-61050	4310-01-184-7537	10	9
55921	C70112-61070	5365-01-208-6927	10	10
			11	10
55921	C70112-61120	4310-01-204-8406	10	11
55921	C70112-61210		10	16
			11	16
55921	C70112-61250	5306-01-207-7529	10	15
			11	15

NATIONAL STOCK NUMBER AND PART NUMBER INDEX				
FSCM	PART NUMBER	PART NUMBER INDEX		
		STOCK NUMBER	FIG.	ITEM
55921	C70112-76210	5310-01-208-6733	4	2
55921	C70122-57030		12	7
55921	C70122-57040	5330-01-207-9423	12	8
55921	C70122-57060		12	3
55921	C70122-57070	5330-01-207-9422	12	4
55921	C70122-57080	5330-01-207-9375	12	6
55921	C70122-61280		10	14
			11	14
55921	C70122-87010	4730-01-206-3546	8	2
55921	C70132-56010		12	10
55921	C70132-57010		12	11
55921	C70132-76010		4	1
55921	C70132-87030	4730-01-204-7945	8	5
55921	C70132-87100	4710-01-204-5311	8	4
55921	C70172-12010		11	2
55921	C70172-32070	5360-01-210-6554	9	5
55921	C70172-42070	5360-01-209-7612	9	3
55921	C70172-52010		11	6
55921	C70172-62010	4310-01-205-9492	11	12
55921	C70172-62120	4310-01-204-5242	11	11
55921	C70172-87100		8	3
55921	C70172-87300		8	1
55921	C91501-1308020		10	4
			11	4
			12	1
55921	C91505-1308025	5306-01-207-9308	4	3
			10	1
			11	1
55921	C91505-2304010		10	13
		5305-01-208-5210	11	13
55921	C92513-150400	5310-01-208-2898	6	2
55921	C92521-150400	5310-01-208-0289	6	3
52034	DTD2-22-72-DE1-10	5930-01-210-8734	1	11
52034	DT2RRESETDC1		1	12
23826	D27257-1		2	2
23826	D274-1		2	8
23826	D334-1		2	5
23826	D354-1		2	4
23826	D661-0-7		2	7
23826	D661-0-8		2	6
23826	D817-2		2	3
81348	GG-G-91	4910-00-522-3778	17	2
76241	JAX7/8	5365-01-208-6941	4	5
* 96906	MS25082-3	5310-00-655-6930	14	2
96906	MS25782-5	4820-00-849-1220	15	15
96906	MS35206-261	5305-00-984-6208	3	7
96906	MS35338-44	5310-00-582-5965	1	9
			3	3
96906	MS35338-45	5310-00-407-9566	3	10
			5	2
			13	2

NATIONAL STOCK NUMBER AND PART NUMBER INDEX				
FSCM	PART NUMBER INDEX			
	PART NUMBER	STOCK NUMBER	FIG.	ITEM
96906	MS35649-2312	5310-00-829-9981	13	1
96906	MS35751-41	5306-00-721-5944	13	3
96906	MS39230-3	4730-00-253-4413	15	14
96906	MS39231-2	4730-00-278-4290	15	10
96906	MS51065-48-2	3030-00-983-2873	4	4
96906	MS51861-22	5305-00-432-8027	18	1
96906	MS51884-3	4730-00-187-4207	7	4
			16	2
96906	MS51887-9	4730-00-204-3481	15	4
96906	MS51953-25	4730-00-196-1465	15	3
96906	MS51953-29	4730-00-196-1502	7	6
			15	1
96906	MS51953-52	4730-00-761-8538	15	12
96906	MS51953-73	4730-00-921-3612	15	6
96906	MS51967-2	5310-00-761-6882	1	8
			3	2
96906	MS51967-5	5310-00-880-7744	3	9
96906	MS90728-32	5306-00-226-4825	3	11
96906	MS90728-34	5306-00-226-4827	5	1
96906	MS90728-6	5305-00-068-0508	1	7
			3	6
58818	NC25-70	4310-00-165-0579	16	1
93236	PL12M	4730-00-249-3915	7	5
55921	QA-6-8-83		18	3
55921	QA-6-9-83		18	2
58818	SV-33-3/8-200		15	11
55921	VA1602		8	7
55921	VE1006-24		1	5
55921	VE1015-11.5		1	22
55921	VE1031-14		1	4
55921	VE1037-24		1	23
55921	VR318	4720-01-204-8374	17	1
78229	XC-491	5975-00-152-1122	1	6
55921	OFB875		8	6
55921	OFC232		15	16
55921	OFC233	3020-01-204-8133	4	6
55921	OF606		1	1
55921	OF607		1	19
92940	04A091010200	3110-00-533-9592	14	19
92940	04A091010400	3110-01-172-1795	14	5
61349	046778	6685-00-264-3961	15	9
92940	07C034710303		14	21
79136	10-100-0240	5365-01-209-9711	9	7
79136	10-100-0300	5365-01-208-6926	9	14
72423	1021-060	4730-00-249-2030	15	13
92940	11B037270100		14	24
92940	12A045940300		14	4
92940	12B037260100		14	22
52034	1414PHG6		1	16
92679	144127	4730-00-278-4284	15	2
92940	15A088402200		14	7

NATIONAL STOCK NUMBER AND PART NUMBER INDEX				
FSCM	PART NUMBER	PART NUMBER INDEX		
		STOCK NUMBER	FIG.	ITEM
92940	16B037370100		14	10
92940	16B045990100		14	8
92940	19A012543200		14	25
21335	205K	3110-00-554-5403	12	9
52034	22.601.304-120V	5950-01-203-8496	1	14
92940	22A022920300		14	6
92940	23A02741900	5315-01-210-6545	14	3
92940	24A092850300		14	23
* 11530	258-2384	5975-00-296-0534	1	18
92940	28A093170100		14	20
92940	29A082870100		14	17
92940	29A093280100		14	9
92940	29A093290100		14	11
59730	391	5970-01-087-7328	1	21
59730	393	5970-01-204-4641	1	3
95535	55229	4710-00-424-2694	BULK	1
86107	592-14	4820-00-403-4658	15	5
92940	606331	6105-01-182-8872	13	4
23826	69HAU1	5930-00-539-2108	2	1
79470	69X4	4730-00-287-1766	15	8
03743	7245V	5975-00-681-0531	1	24
03743	7246V	5975-00-243-4491	1	2
23826	75HA69	5930-00-521-8471	2	
92940	93A113114100	5999-01-205-2039	14	18
92940	93A120018002		14	12
92940	93A120118003		14	15
92940	93A120387001		14	14
92940	93B208465001		14	16
92940	93B240681006		14	26
92940	93C304673501		14	1
92940	93C305766003		14	13

By Order of the Secretary of the Army:

JOHN A. WICKHAM, JR.
General, United States Army
Chief of Staff

Official:

R. L. DILWORTH
Brigadier General, United States Army
The Adjutant General

DISTRIBUTION:

To be distributed in accordance with DA Form 12-25A, Organizational, and Direct Support and General Support Maintenance Requirements for Compressor Unit, Reciprocating, Electric, 5 CFM, 175 PSI (E23CV7A).

RECOMMENDED CHANGES TO EQUIPMENT TECHNICAL PUBLICATIONS



THEN... JOT DOWN THE DOPE ABOUT IT ON THIS FORM. CAREFULLY TEAR IT OUT. FOLD IT AND DROP IT IN THE MAIL!

SOMETHING WRONG WITH THIS PUBLICATION?

FROM: (PRINT YOUR UNIT'S COMPLETE ADDRESS)
PFC JOHN DOE
COA, 3d ENGINEER BN
FT. LEONARDWOOD, MO 63108

DATE SENT

PUBLICATION NUMBER
 TM 5-4310-377-23P

PUBLICATION DATE
 10 Mar 86

PUBLICATION TITLE Compressor Unit,
 Reciprocating, 5 CFM, 175 PSI

BE EXACT... PIN-POINT WHERE IT IS

PAGE NO	PARA-GRAPH	FIGURE NO	TABLE NO
6	2-1 a		
B1		4-3	
125	line 20		

IN THIS SPACE TELL WHAT IS WRONG AND WHAT SHOULD BE DONE ABOUT IT:

In line 6 of paragraph 2-1a the manual states the engine has 6 cylinders. The engine on my set only has 4 cylinders. Change the manual to show 4 cylinders.

Callout 16 on figure 4-3 is pointing at a bolt. In key to figure 4-3, item 16 is called a shim - Please correct one or the other.

I ordered a gasket, item 19 on figure B-16 by NSN 2 910-00-762-3001. I got a gasket but it doesn't fit. Supply says I got what I ordered, so the NSN is wrong. Please give me a good NSN

PRINTED NAME, GRADE OR TITLE, AND TELEPHONE NUMBER

JOHN DOE, PFC (268) 317-7111

SIGN HERE

JOHN DOE

DA FORM 2028-2
 1 JUL 79

PREVIOUS EDITIONS ARE OBSOLETE.
 DRSTS-M Overprint 1, 1 Nov 80

P.S.-IF YOUR OUTFIT WANTS TO KNOW ABOUT YOUR RECOMMENDATION MAKE A CARBON COPY OF THIS AND GIVE IT TO YOUR HEADQUARTERS.

TEAR ALONG PERFORATED LINE

RECOMMENDED CHANGES TO EQUIPMENT TECHNICAL PUBLICATIONS



THEN... JOT DOWN THE DOPE ABOUT IT ON THIS FORM, CAREFULLY TEAR IT OUT, FOLD IT AND DROP IT IN THE MAIL!

SOMETHING WRONG WITH THIS PUBLICATION?

FROM: (PRINT YOUR UNIT'S COMPLETE ADDRESS)

DATE SENT

PUBLICATION NUMBER
TM 5-4310-377-23P

PUBLICATION DATE
10 Mar 86

PUBLICATION TITLE
Compressor Unit,
Reciprocating, 5 CFM, 175 PSI

BE EXACT... PIN-POINT WHERE IT IS

PAGE NO.	PARA-GRAPH	FIGURE NO.	TABLE NO.

IN THIS SPACE TELL WHAT IS WRONG AND WHAT SHOULD BE DONE ABOUT IT:

TEAR ALONG PERFORATED LINE

PRINTED NAME, GRADE OR TITLE, AND TELEPHONE NUMBER

SIGN HERE:

DA FORM 1 JUL 79 2028-2

PREVIOUS EDITIONS ARE OBSOLETE.
DRSTS-M Overprint 2, 1 Nov 80.

P.S.--IF YOUR OUTFIT WANTS TO KNOW ABOUT YOUR RECOMMENDATION MAKE A CARBON COPY OF THIS AND GIVE IT TO YOUR HEADQUARTERS.

REVERSE OF DA FORM 2028-2 Reverse of DRSTS-M Overprint 2,
1 Nov 80

FILL IN YOUR
UNIT'S ADDRESS

FOLD BACK

DEPARTMENT OF THE ARMY

OFFICIAL BUSINESS
PENALTY FOR PRIVATE USE \$300

POSTAGE AND FEES PAID
DEPARTMENT OF THE ARMY
DOD 314



TEAR ALONG PERFORATED LINE

COMMANDER
U S ARMY TROOP SUPPORT COMMAND
ATTN: AMSTR-MCTS
4300 GOODFELLOW BOULEVARD
ST. LOUIS, MO 63120-1798

The Metric System and Equivalents

Linear Measure

1 centimeter = 10 millimeters = .39 inch
 1 decimeter = 10 centimeters = 3.94 inches
 1 meter = 10 decimeters = 39.37 inches
 1 dekameter = 10 Meters = 32.8 feet
 1 hectometer = 10 dekameters = 328.08 feet
 1 kilometer = 10 hectometers = 3,280.8 feet

Weights

1 centigram = 10 milligrams = .15 grain
 1 decigram = 10 centigrams = 1.54 grains
 1 gram = 10 decigram = 0.35 ounce
 1 dekegram = 10 Grams = .35 ounce
 1 hectogram = 10 dekagrams = 3.52 ounces
 1 kilogram = 10 hectograms = 2.2 pounds
 1 quintal = 100 kilograms = 220.46 pounds
 1 metric ton = 10 quintals = 1.1 short tons

Liquid Measure

1 centiliter = 10 milliliters = .34 fluid ounce
 1 deciliter = 10 centiliters = 3.38 fluid ounces
 1 liter = 10 deciliters = 33.81 fluid ounces
 1 dekaliter = 10 liters = 2.64 gallons
 1 hectoliter = 10 dekaliters = 27.42 gallons
 1 kiloliter = 10 hectoliters = 264.18 gallons

Square Measure

1 sq. centimeter = 100 sq millimeters = .155 sq. inch
 1 sq. decimeter = 100 sq centimeters = 125.5 sq. inches
 1 sq. meter (centare) = 100 sq decimeters = 10.76 sq. feet
 1 sq. dekameter (are) = 1,076.4 sq. feet
 1 sq. hectometer (hectare) = 100 sq. dekameters = 2.47 acres
 1 sq. kilometer = 100 sq. hectometers = .386 sq. mile

Cubic Measure

1 cu. centimeter = 1000 cu. millimeters = .06 cu. inch
 1 cu. decimeter = 1000 cu. decimeters = 61.02 cu. inches
 1 cu. meter = 1000 cu. decimeters = 35.31 cu. feet

Approximate Conversion Factors

<i>To change</i>	<i>To</i>	<i>Multiply by</i>	<i>To change</i>	<i>To</i>	<i>Multiply by</i>
inches	centimeters	2.540	ounce-inches	newton-meters	.007062
feet	meters	.305	centimeters	inches	.394
yards	meters	.914	meters	feet	3.280
miles	kilometers	1.609	meters	yards	1.094
square inches	square centimeters	6.451	kilometers	miles	.621
square feet	square meters	.093	square centimeters	square inches	.155
square yards	square meters	.836	square meters	square feet	10.764
square miles	square kilometers	2.590	square meters	square yards	1.196
acres	square hectometers	.405	square kilometers	square miles	.386
cubic feet	cubic meters	.028	square hectometers	acres	2.471
cubic yards	cubic meters	.765	cubic meters	cubic feet	35.315
fluid ounces	milliliters	29.573	cubic meters	cubic yards	1.308
pints	liters	.473	milliliters	fluid ounces	.034
quarts	liters	.946	liters	pints	2.113
gallons	liters	3.785	liters	quarts	1.057
ounces	grams	28.349	liters	gallons	.264
pounds	kilograms	.454	grams	ounces	.035
short tons	metric tons	.907	kilograms	pounds	2.205
pound-feet	newton-meters	1.365	metric tons	short tons	1.102
pounds-inches	newton-meters	.11375			

Temperature (Exact)

°F Fahrenheit Temperature 5/9 (after subtracting 32) Celsius Temperature °C

TM 5-4310-377-23P

PIN: 059614-000